

DIY



How to build Hebel PowerFence



NEW easy PowerFence

The innovative alternative to brick makes masonry fencing easy and affordable - and an ideal fencing system for DIY.

Hebel PowerFence is an attractive and versatile fence system that provides an efficient and effective privacy and noise barrier for residential applications.

Perfect for boundary fencing and low front walls, Hebel PowerFence provides a modular masonry structure using lightweight panels and steel posts which can be easily and quickly erected without the need for extensive excavation or strip footings, as is normally the case for traditional masonry fence construction.

Hebel PowerFence can be finished in either Expressed or Monolithic and can also be adapted to include a range of different decorative treatments such as timber panels or ironwork.

The new PowerFence system uses a specially designed PowerFence Bracket, allowing the single square post to be used for a large variety of fence configurations. The PowerFence Bracket can be rotated around the post for easy installation of corners. The brackets can be separated vertically on the post to allow panels to be 'stepped' for sloping terrain.

PowerFence:

- is simple, cost effective and attractive
- creates privacy and acts as reflective noise barrier system
- perfect for boundary fencing and as an alternative to brick or block masonry for front fences
- can be decorated with a range of profiles and looks to provide design flexibility
- is non combustibile and termite resistant – the perfect choice for bushfire prone areas
- uses 75mm Hebel PowerPanel, with specially coated reinforcement to deter corrosion and provide maximum durability
- is engineered for the majority of conditions in urban Australia.

Can be finished with a choice of expressed joints or a monolithic look.

Expressed for accentuated panel joints and simpler final coating

The top of the fence is capped using a 76mm galvanized steel U Channel.

Panels are easily hand bevelled to give 'V' jointed horizontal lines between panels.

Hebel blocks may be cut and placed on top of each post for further detail.

Front and rear of posts are concealed by PowerFence compressed fibre cement post covers of 15mm thickness.

Monolithic for a uniform 'fully rendered' look

The top of the fence is capped with Hebel blocks.

Capping blocks can be cut to size using a handsaw. Blocks are laid end to end and must be glued together using Hebel Adhesive or a suitable construction adhesive.

Front and rear of posts are concealed by PowerFence compressed fibre cement post covers of 15mm thickness.



Why use the new Hebel PowerFence?

1. New PowerFence can now be built with the standard Hebel PowerPanel – for a better priced fencing system

The new PowerFence system meets the majority of environmental conditions for suburban fencing in urban Australia using standard 1800 x 600 x 75mm Hebel PowerPanels. Under stricter conditions the 2400 x 600 x 75mm standard PowerPanel can be used. See Table 1.

2. New PowerFence uses a single common 75 x 75mm square section steel post – again for a more economical Hebel fencing system

The new PowerFence system requires only one standard post, for all fence configurations. This new universal post is less expensive than the original system and as it's universal in design, ordering and delivery is simplified.

3. New PowerFence is now easier to fabricate corners and easier to install on sloping ground

PowerFence uses a new design PowerFence Bracket. The same PowerFence Bracket can be turned upside down to form a starting cleat for the panels, as well as being a lateral support bracket for all panels. The PowerFence Bracket can be rotated around the post, to allow the installer to easily turn the fence around corners. In addition, the brackets can be separated vertically on the post to allow panels to be 'stepped' and follow sloping terrain.

4. New PowerFence is now safer to install, especially for DIY and the individual builder

The PowerFence Bracket is designed to temporarily secure the panels laterally during installation. This means that as soon as a panel is placed and the PowerFence Bracket is dropped over the panel, the bracket will safely hold that panel in place until the permanent fixings and post covers are installed.

5. New PowerFence is now adjustable during construction in many ways

The PowerFence Bracket is a universal component, which means that if required, it can be easily repositioned and re-fixed during construction. This is a real advantage for DIY or builders installing PowerFence for the first time.

6. Simplified connections using the same screw

New PowerFence uses the same screw fixing for both attaching the bracket and attaching the final post covers. This further simplifies construction.

7. New PowerFence is faster to install

The universal posts, the adjustable brackets and the use of lighter 1800 x 600 panels, all combine to make the new PowerFence system much faster to install.

8. New PowerFence is DIY friendly

We know that many people want to buy and install PowerFence, but the original PowerFence system was difficult for DIYers to manage the installation. With the new PowerFence system it's easily handled by two people working in a home environment with common workshop tools - and the components are less expensive.

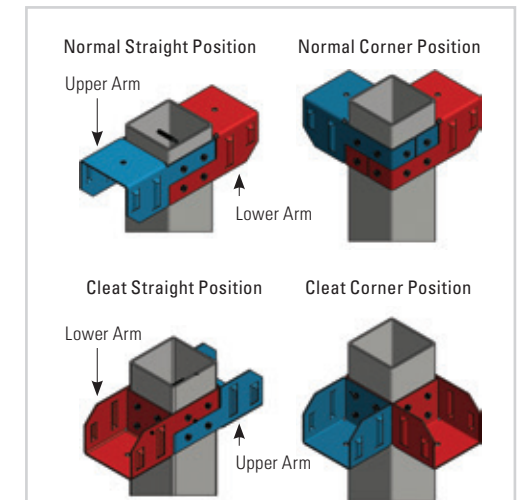
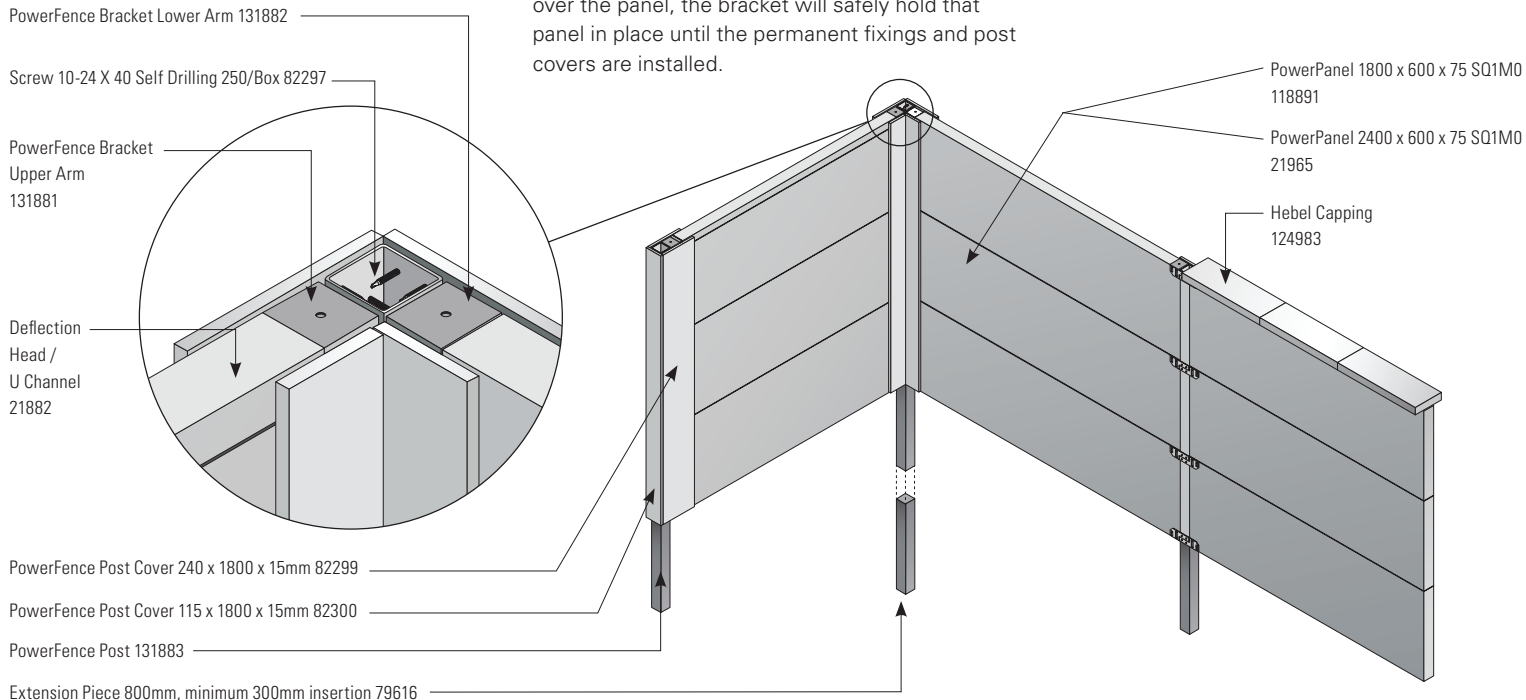

The versatile Hebel PowerFence Bracket

Multi-purpose and adjustable for all-round easier and safer construction. Move it up or down while constructing. Rotate it to make a corner. Turn it upside down for a starting cleat. Use it as a lateral support for all the panels. Separate its two integrated sections for stepped or terraced fencing. Reposition and refix if need be, as you go.

Hebel PowerFence Bracket patent pending.

STEP 1

Determining soil type and required post depth

Refer to Table 1 below. This table is a general guide based on broad soil types and terrain categories. We recommend you consult a relevant engineer or local authority to confirm relevant soil type and the terrain category/wind loads in your area.

STEP 2

Setting out the fence

Mark out the entire fence project on your property measuring the post spacings along this alignment.

The standard PowerFence system is designed for 1800mm long panels, requiring post spacings of 1885mm, from post centre to post centre. PowerFence bay lengths can be less than 1800mm, and under more strict conditions (see Table 1), increased to an absolute maximum of 2400mm panel length.

For other bay sizes, the post set out (centre to centre) is always the panel length in mm, plus 10mm (5mm space at each panel end) plus 75mm. For example - a maximum length 2400mm panel post set out would be 2485mm centre to centre.

Table 1 - Hebel PowerFence Required Footing Embedments

| Wind Load | Site Category | Terrain Category 2 | | | Terrain Category 3 | | | |
|-----------------------|--------------------------------|--|----------------------------|---------|--------------------|----------------------------|---------|--------|
| | Location | Free End | Corner End | General | Free End | Corner End | General | |
| | Ultimate Wind Pressure Wu* | 2.00kPa | 1.50kPa | 1.09kPa | 1.67kPa | 1.25kPa | 0.90kPa | |
| | Service Wind Pressure Ws | 1.63kPa | 1.22kPa | 0.88kPa | 1.36kPa | 1.02kPa | 0.74kPa | |
| Post Spacing = 2400mm | Required Post Section = | | 75x75x2.5 SHS -C350 | | | 75x75x2.5 SHS -C350 | | |
| | Required Footing embedment | Soil Type 1 (Soft Clay ABC =100kPa Cu=50kPa) | 1100 mm | 900 mm | 800 mm | 1000 mm | 800 mm | 700 mm |
| | | Soil Type 2 (Firm Clay ABC =200Pa Cu=100kPa) | 800 mm | 700 mm | 600 mm | 700 mm | 600 mm | 500 mm |
| | | Soil Type 3 (Very Stiff Clay ABC = 300kPa Cu=150kPa) | 600 mm | 600 mm | 500 mm | 600 mm | 500 mm | 450 mm |
| Post Spacing = 1800mm | Required Post Section = | | 75x75x2.5 SHS -C350 | | | 75x75x2.5 SHS -C350 | | |
| | Required Footing embedment | Soil Type 1 (Soft Clay ABC =100kPa Cu=50kPa) | 900 mm | 800 mm | 700 mm | 800 mm | 700 mm | 600 mm |
| | | Soil Type 2 (Firm Clay ABC =200Pa Cu=100kPa) | 700 mm | 600 mm | 500 mm | 600 mm | 500 mm | 450 mm |
| | | Soil Type 3 (Very Stiff Clay ABC = 300kPa Cu=150kPa) | 600 mm | 500 mm | 450 mm | 500 mm | 450 mm | 400 mm |

Note: 1. Wind loads in the table are in compliance with AS1170.2-2011 2. Post Section to be SHS 350mPa Grade to AS1163. 3. 'Free end' denotes within 2xh length from the end of wall, including gap and gate in the wall, 'Corner End' denotes within 2xh length at a corner with a return wall; 'General' denotes all other situations. 4. Pier footing is 300mm dia. Grade 20mPa concrete with steep post embedded to within 50mm - 100mm from the bottom of pier. 5. If soil condition is encountered other than specified in table, specialist advice is required.



STEP 3

Installing posts

Dig 300mm diameter post holes ensuring correct hole depth for the required post embedment. See Table 1 for details.

Place posts in holes ensuring each post is plumb, holding posts in place with temporary supports.

Pour in concrete around the post bases up to ground level, allowing concrete to set.

PowerFence Posts are supplied as 2400mm long for an 1800mm exposed fence height and a minimum 600mm embedment.

Note: If embedment requirements exceed 600mm then simply fix an 800mm length of Power Fence 65mm x 65mm x 2.5 SHS post extension, using screws or bolts. See Fig.3.4

Slide the extension into the PowerFence Post, and adjust the extension to protrude from the base of the PowerFence post to ensure the total embedment depth required. The extension must have a minimum 300mm inserted into the PowerFence Post. Ensure the extension is screwed or fixed on at least two sides of the PowerFence Post. See Fig 3.4

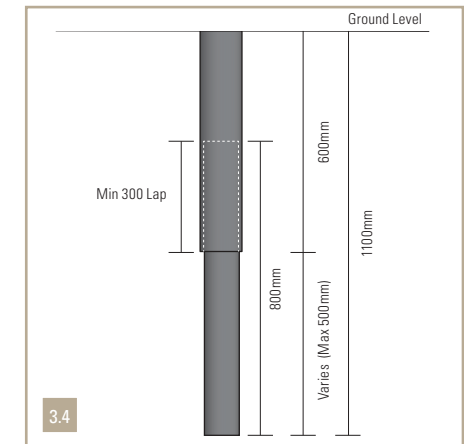



STEP 4

Setting PowerPanel levels

Place a string line along posts at the base level of the fence (Fig 4.1).

Turn a PowerFence Bracket upside down to form the cleat position. Put this over the top of post, sliding it down the post so the base of the cleat plate is in line with the string line. Fix off the cleat to the post with screws (Fig 4.2).

It's best to only fix cleats one bay ahead of the bay being installed, allowing for minor adjustments as the fence is built (Fig 4.3).



STEP 5

Installing PowerPanels

With the starting cleat in place on both posts of a fence bay, the first PowerPanel can be installed.

Place the PowerPanel on the cleats and have another PowerFence Bracket ready in the normal lateral-fix position (Fig 5.1).

Slide bracket down the post and drop over the top of the first panel to temporarily lock the panel to the post and stop the panel from falling either side. There's no need to permanently fix any lateral brackets with screws until just before installing the final post covers (Fig 5.2).

Continue to install panels along the fence using a notched trowel bed of Hebel Adhesive between the horizontal joints of all panels (Fig 5.3 & 5.4).

PowerFence can be built a single bay at a time, but it's generally easier and faster to install each row of panels along the entire fence length at a time. When building PowerFence a bay at a time it is important to slide both sides of the brackets on to the posts as each panel is stacked in the



bay. This way the PowerFence Bracket is already in the right place for the next bay. These brackets are then simply lifted by sliding up the post and dropping over the panels as the next bay is installed (Fig 5.5 & 5.6).

The PowerFence Bracket system is designed as a pair, with both brackets identical except one has an upper arm and the other a lower arm to connect to the post. This is so the brackets can be combined in a range of configurations - from normal level ground, around corners and sloping ground.

NOTE: PowerFence has a maximum height of 1800mm and normally 3 x 600mm wide PowerPanels are stacked horizontally. For any height over 1800mm, an engineer must be consulted for a specific design of both the post and the supportive base cleat.

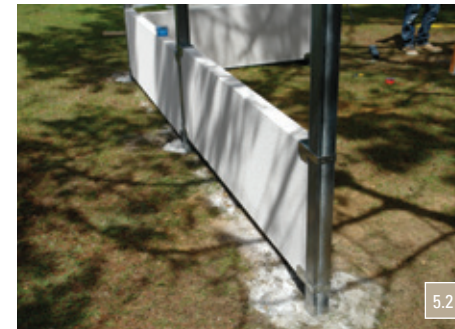

STEP 6

Sloping ground and angle corners

When building a fence at a 90° corner simply follow Fig 6.1, 6.2 and 6.3.

For sloping ground fix the PowerFence Bracket starting cleat in the correct position to follow the sloping terrain.

The vertical step between each bay shouldn't exceed 200mm (approx 15 degree slope).

When installing on sloping ground it's important to follow a set sequence with each PowerFence Bracket pair ensuring the correct 'ready' position of a bracket for the next bay.

When climbing sloping ground, always install the lower arm bracket first, then slide the adjacent upper arm bracket down the post and leave unfixed. It can then be lifted to fit over the panel in the next 'higher' adjacent bay. Conversely, when descending a slope, slide the lower arm bracket over the post first and leave loose. Then drop the upper arm bracket over the panel being installed. This way, the lower arm bracket is already in position to accept the panel in the next adjacent 'lower' level bay.

Angle turns are achieved by embedding two posts close together at the required turn of angle and installing the panels at the splayed corner like an end bay. The two closely aligned posts are then fully covered on both sides using PowerFence Post Covers and screw fixings.



6.1



6.2



6.3

STEP 7

Completing the connections and covering PowerFence Posts

After the fence is assembled and all the panels glued together, complete all bracket connections by screw fixing the bracket arms to posts using two screws for each side.

Fix the PowerFence Post Covers over the PowerFence Bracket arms and screw fix the post covers directly to the post using the 10-24 x 40mm countersink head screws. Pre-drill and countersink pilot holes into the compressed fibre cement post covers prior to screw installation - so the screw heads finish flush with the post covers

Use 150mm vertical screw spacings at all corners and end posts, and 150mm centres on other intermediate posts.

For end bays simply finish with a PowerBracket set on the PowerPanel side of the end post. Then cover all three exposed sides with PowerFence Post Covers, screw fixing the end post cover to the post at 150mm centres.

This completes the structural system for each post.

To make installation easier, pilot holes can also be drilled in the steel posts before fixing screws, using the countersunk drilled post covers as a template.

On sloping ground it may be necessary to place an additional cut section of post cover to ensure the stepped panels are completely covered.

Post covers are made from thick fibre cement, and therefore can be cut using the same diamond turbo blade on a circular saw as the Hebel PowerPanel. The post covers should be cut slowly, passing along the cut several times and increasing the cut depth of the saw by a few mm on each pass. Always use a guide fence with the saw to ensure straight neat cuts.

Hearing and respiratory protection is also necessary during cutting.



7.1



STEP 8

Decorative panel capping and post caps

There's a variety of ways to decoratively complete PowerFence.

Panels can be easily capped and strengthened using 76 x 50 galvanised 'U Channel', which is placed over the top of each panel and glued into place with construction adhesive. Ensure there is 5mm of expansion space at the ends of each capping length, as with the panels (Fig 8.1).

To finish the tops of posts, a 600 x 200 x 50mm Hebel block can be used. Cut in half to make a 300 x 200 x 50mm cap, glue and screw fix over the post. When fixing post caps into the Hebel panel use a 100mm, 14-10 bugle head type 17 screw. Pre-drill the post cap, glue the post cap down with Hebel Adhesive and screw fix into place (Fig 8.2, Fig 8.3, Fig 8.4).

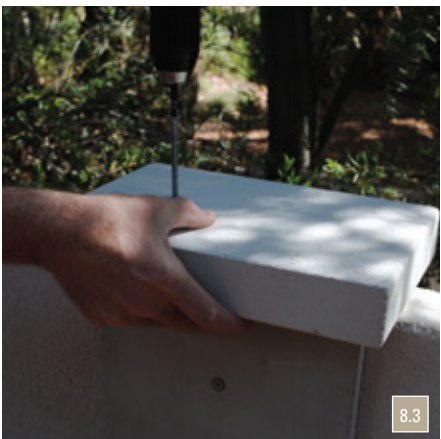

STEP 9

Finishing and coatings

PowerFence can be finished using either roll on flexible exterior paints or texture coat finishes. If a supportive galvanized panel capping has been used then no further protection along the top of the panel is required. However, if the PowerPanel itself is the top edge of the fence, Hebel recommends the top of all panels and 100mm either side of the panel from the top, be first coated with an exterior grade waterproofing compound. This should be compatible with the final coating system. It will further protect the panel from water ingress, maximizing the life of the coating system used.



Visit www.hebel.com.au and view our How to build a Hebel PowerFence video.

Cutting PowerFence

- PowerFence panels are cut using a circular blade power saw fitted with a diamond encrusted, continuous rim, 'turbo' sided masonry blade and preferably a vacuum dust extraction system.
- A straight edge cutting fence or square should be used to ensure straight cross-cuts that are perpendicular to the panel length. Set the blade to cut at a 72mm depth and then cut all 75mm panels laid flat horizontally with full support underneath. There is no need to cut totally through the entire panel thickness – the last couple of mm thickness will simply and easily break away.
- Note: cutting will expose the internal steel reinforcement inside the Hebel PowerPanel. This exposed steel must be re-coated by simply painting on a layer of Hebel Anti-Corrosion Paint.

System components

PowerPanel for fence panels

The primary component of the standard PowerFence system is the 1800mm long by 600mm wide and 75mm thick, steel-reinforced Hebel PowerPanel.

PowerFence Bracket

The Hebel PowerFence Bracket acts as the supportive cleat for base panels and the lateral restraint for all other panels as they are positioned between posts.

PowerFence Capping

For maximum weatherproofing and a stronger finish to the top edge, PowerFence panels can be quickly and simply capped with a purpose made, galvanized steel, 76 x 50mm 'U' shaped capping channel

PowerFence Posts

PowerFence Posts are 75mm x 75mm x 2.5mm galvanized box section steel. They are supplied in a standard 2.4m length to suit up to a 1.8m high fence when anchored in 600mm deep concrete bedded footings.

PowerFence Post Extensions

Where deeper footings are required a post extension piece is available. This easily connects to the base of a standard PowerFence Post.

Note: Extension pieces are only used to increase the embedment depth of the post in the ground – the maximum fence height for standard PowerFence posts is always a max. of 1800mm.

PowerFence Post Covers

To complete the structural design of PowerFence, sturdy 15mm compressed fibre cement panels are screw fixed onto each side of the steel posts. These complete the structure and also decoratively cover the PowerFence Brackets to create an attractive 'engaged pier' appearance that further emulates the look of a solid masonry fence.

Hebel Capping Blocks for PowerFence Posts

To cover the tops of posts Hebel manufactures 50mm thick solid capping blocks. Simply cut and fix to the top of the fence panels next to the post and create a solid 'capital' over the fibre cement covers.

Screws

1. 10–24 x 40mm: self-drilling metal screw, countersink head. For connecting bracket to post and post cover to post.
2. 14-10 x 100mm: needle point screw, bugle or hex head. For any fence capping to Hebel panel connection.

Hebel Adhesive

20kg Bags – for glueing together of all Hebel components, both panels and blocks.

Hebel Patch

10 kg bags. For repair of any holes or construction damage to Hebel blocks or panels - prior to final coating

Construction Adhesive

Selleys Liquid Nails or Fullers Max Bond – for glueing metal fence capping and post covers to metal posts.

Hebel Anti-Corrosion Paint

For protection of any exposed reinforcing steel when cutting panels.

Decorative coatings

Hebel PowerFence should be finally coated with a flexible exterior acrylic paint or render system.

Bagged concrete

To cement posts into the ground.

Tools required

- cordless drill / driver
- power saw fitted with a diamond encrusted continuous rim 'turbo' masonry blade
- rubber mallet, trowel, old handsaw, tin snips
- tape measure, marker pen, level, string line, clamps

Useful construction notes

- When the Hebel PowerFence is in contact with the ground a suitable waterproofing membrane must be used on the panels that will be covered by, or exposed to, ground soil. The waterproofing is applied to both sides, the base and vertical ends of the panel to a minimum height of 100mm above the finished ground level.
- PowerFence panels may be cut along the panel length to a minimum width of 270mm. PowerPanel can be docked in length to suit the bay width.
- Paint any steel reinforcement exposed by cutting with Hebel Anti-Corrosion Paint. If the top panel has been cut along the length, it is best practice to place that panel with the cut side facing down.
- Patch any holes and damage to the panels with Hebel Patch prior to coating.
- Vertical movement joints require a knife cut in the base coat render prior to application of the final flexible surface coating - to allow differential movement between panels and posts without cracking the coating system.
- All top capping blocks, and / or steel capping channels, are to be glued and screwed in place using adhesive and 14-10x100mm bugle head type 17 screws. Capping blocks above posts must have saw cuts either side of each post to allow movement without cracking of the capping structure. These movement joints must be filled with a suitable exterior sealant and the coating systems must allow movement without cracking of the render or texture.
- Fixing of decorative panels to or across posts and any capping blocks should be done in a way that permits differential movement.

Important Safety notes

Hebel products are cement based, which may irritate the skin. The wearing of gloves and suitable clothing to reduce the risk of skin irritation is recommended when handling Hebel products.

The use of power tools when cutting concrete or cement based products may cause dust containing respirable crystalline silica, and as with all masonry concrete, this fine dust has the potential to cause bronchitis, silicosis and lung cancer after repeated and prolonged exposure.

1. When using hand or power tools on Hebel products a P1 or P2 respirator and eye protection must be worn.
2. Additionally when using power tools for cutting, routing or chasing Hebel products, the use of dust extraction and the wearing of hearing protection is required.
3. Hebel panels are despatched in vertically bundled packs, fully strapped for stability. Prior to the cutting of the strapping, the vertical panel bundles should be stabilised with temporary restraints such as sash clamps, ratchet straps or Hebel stabilising bars. This will prevent panels from toppling over and reduces the risk of panel damage or injury. Care should be taken to ensure panels do not topple when removing individual panels from bundles.

4. Refer to the CSR Hebel MSDS and Safe Work Method Statements for guidelines on safe handling practices for Hebel products - available from www.hebel.com.au
5. Hebel PowerFence is designed as a non load-bearing fence system to withstand wind and weather conditions as per Table 1 in this guide. As such, do not stand on capping blocks or the fence itself. Do not use panels themselves as a support or temporary scaffold, and always carry panels around the site oriented on edge. Avoid laying or storing panels horizontally unless fully supported underneath.

Frequently Asked Questions

1. Can I install PowerFence on sloping or uneven ground?

YES. Simply fix the PowerFence Bracket starting cleat in the correct position to follow the sloping terrain. The vertical step between each bay shouldn't exceed 200mm (approximately 15 degree slope). For full instructions see Step 6 in the DIY Guide.

2. Can I change the direction of PowerFence to any angle?

YES. You can achieve angle turns by embedding two posts close together at the required turn of angle and installing the panels at the splayed corner like an end bay. The two closely aligned posts are then fully covered on both sides using PowerFence Post Covers and screw fixings.

3. Can I use PowerFence as a retaining wall?

NO. Although the backfilling of light soils along the base is permitted, PowerFence isn't suitable as a structural soil retaining wall. The reason is straightforward - PowerFence is made of autoclaved aerated concrete (AAC) which is too lightweight to be an effective long-term structural barrier against the high mass and pressure of deep, wet soils or clay.

4. Can I place PowerFence panels directly onto the ground?

YES with waterproofing. The base of the fence should be coated with a suitable exterior waterproofing compound. This is to protect the panel in the long term, and importantly, maximise the life of the coatings you use to complete the fence.

5. Can I install PowerFence higher than 1.8m in height?

YES with engineering consultancy. The standard PowerFence system is engineered to a maximum 1800mm (or 6ft) height when using the PowerFence Post and three standard 1800 x 600 x 75mm PowerPanels, slacked horizontally. For all fence heights above 1800mm you need to consult an engineer for a specific design of both the post and supportive base cleat.

6. Is it possible to install PowerFence at lower heights?

YES. PowerPanel can be cut in both length and width to suit lower fence heights if need be. See Cutting PowerFence in the DIY Guide which includes safety notes.

7. What is the maximum bay length of a PowerFence panel?

PowerFence is designed for the majority of suburban wind loads with an 1800mm bay length. That's one reason why the PowerFence system uses the standard 1800 x 600 x 75mm Hebel PowerPanel.

Under more strict design conditions, PowerFence can be installed in up to 2400mm bay lengths using the 2400 x 600 x 75mm PowerPanel. For more details see Table 1 in the DIY Guide.

8. Can I cut PowerPanels on site?

YES with a minimum 270mm width. See the Cutting PowerFence section in the DIY Guide for details. This includes advice on painting any steel reinforcement exposed with Hebel Anti-Corrosion Paint and important notes on working safety with Hebel.

9. How do I determine my soil type and terrain category for post embedment?

The DIY Guide provides general guidance on broad soil types and terrain categories for PowerFence post embedment. We recommend you contact your local building authority or consult a relevant engineer to find out the type and category for your local area.

10. Can I leave my PowerFence unpainted?

NO. PowerFence must be rendered or painted to ensure maximum weatherproofing of the panels and connections.

11. Do I need to fully render my PowerFence?

GENERALLY NO. PowerFence does not need a thick, troweled-on render finish unless you want to achieve a very flat, monolithic surface finish similar to fully rendered brickwork. PowerFence is more simply and economically finished by coating with a roll-on coloured acrylic texture coat paint.

12. What is special about the PowerFence Bracket?

The PowerFence Bracket is a registered design component (patent pending), which is not only a structural cleat to support the fence panels, but also acts as a lateral support during construction to hold the panels in place immediately after each panel is placed onto the fence. This ensures high safety during installation, particularly for DIY installers.

13. Why do I need Hebel Adhesive between PowerFence Panels?

Hebel Adhesive between the PowerPanels bonds them together so they act as a composite fence bay between posts. This maximises the panel strength and ensures the best substrate for final coating.

14. Is it possible to have different post covers or post decoration?

YES. A range of different finishes can be achieved using Hebel blocks or other decorations, to form a natural chipped stone or engaged pier look to the fence posts. However, the structural fibre cement posts covers must be installed onto PowerFence before any decorations can be applied

15. Do I need to cap PowerFence Posts?

YES. The PowerFence Posts are a square hollow section (SHS) steel and can fill with water unless capped. A number of options are possible. The simplest way is to use a 50mm Hebel block as a capping piece. Best practice is to use a knock-in plastic or knock-on steel cap for the 75mm x 75mm post, then attach a solid capping piece for final decoration. You'll find more information in the DIY Guide.

16. Do I need to cap or treat the top edges of PowerFence panels?

YES. If the PowerPanel is the top edge, Hebel recommends an initial coat of exterior grade waterproofing compound - compatible with the final coating system. It should be applied on the top and down to 100mm either side. This will protect the panel from water ingress maximising the life of the coating system used.