



The better way to build

# Commercial & Industrial Wall Systems

Installation Guide



# Contents

---

1.0	Introduction	3
2.0	Typical Applications	3
3.0	System Components	4
4.0	Delivery and Storage	6
5.0	Panel Handling	7
6.0	System Installation	8
7.0	Construction Details - Horizontal Panels	10
8.0	Construction Details - Vertical Panels	15
9.0	Penetration Details	21
	Appendix A - Installation Checklist	22

# 1.0 Introduction

CSR Panel Systems is a division of CSR Building Products Limited, one of Australia's leading building products companies.

CSR Panel Systems manufactures Hebel® Autoclaved Aerated Concrete (AAC). The AAC in Hebel® products is manufactured from sand, lime and cement to which a gas-forming agent is added. The liberated gas expands the mixture, forming extremely small, finely dispersed air pockets, resulting in lightweight aerated concrete.

CSR Panel Systems has manufactured Hebel® products that have won wide acceptance as innovative and environmentally preferable building materials. This is due to their lightweight nature, excellent thermal, fire and acoustic properties and design versatility. These inherent properties of Hebel® products help achieve quick and cost efficient construction practices as well as providing for comfortable

operating environments inside the buildings all year round.

CSR Panel Systems has developed systems for commercial and industrial applications that harness the benefits of lightweight construction where thermal, acoustic and fire properties are desired.

For further information on Design elements refer to the Commercial and Industrial Walls Design Guide available from [hebel.com.au](http://hebel.com.au)

## 2.0 Typical Applications

Hebel® Commercial and Industrial Wall Systems (CIWS) are designed for application in buildings that have a commercial/industrial type of business activity purpose. These buildings can be shopping centres, schools, sport or assembly halls, factories or factory

units, clubs, plant or generator rooms, sheds, produce storage facilities, etc. The Building Code of Australia (BCA) generally classifies these buildings into class 5, 6d, 7b, 8, 9a and 9b.

Structurally, the CIWS walls are non-loadbearing, external and internal walls made out of Hebel® wall panels. The panels are steel-reinforced and secured to the structural support frame. The structural support frame is typically steel or portal frame, but it can also be concrete framed. The CIWS wall can be finished off with various combinations of external coatings and internal linings to suit project requirements.

There are two types of CIWS walls. The first of these is the CIWS-HZ (See Detail 7.1) in which the panels are assembled horizontally. The second is the CIWS-VT (See Detail 8.1) in which the panels are assembled vertically.

**Image. 2.1 East Gardens Shopping Centre, NSW**



# 3.0 System Components

## 3.1 General System Components

A summary of the components or their equivalents that Hebel® recommends for use in the CIWS is shown in Table 3.1.

**Table 3.1 System components summary.**

System component	CIWS Type		Supplied by CSR Panel Systems
	CIWS-HZ	CIWS-VT	
Hebel® Wall Panel	✓	✓	✓
Hebel® Adhesive	✓	✓ <sup>1</sup>	✓
Hebel® Mortar	✓ <sup>2</sup>	✓ <sup>2</sup>	✓
Hebel® Patch	✓ <sup>2</sup>	✓ <sup>2</sup>	✓
Anticorrosion Coating Agent	✓ <sup>2</sup>	✓ <sup>2</sup>	✓
DPC or Bond Breaker	✓ <sup>2</sup>	✓ <sup>2</sup>	
Steel Base Angle	✓ <sup>2</sup>	✓ <sup>2</sup>	
Fasteners/Fixings	✓	✓	✓ <sup>3</sup>
Fire/Acoustic Sealants	✓	✓	
Gyprock™ Plasterboard	✓ <sup>1</sup>	✓ <sup>1</sup>	
Coating Systems	✓ <sup>1</sup>	✓ <sup>1</sup>	
Hebel® HighBuild	✓ <sup>1</sup>	✓ <sup>1</sup>	✓

Note:

<sup>1</sup> Optional use as specified by project consultants.

<sup>2</sup> Use as required.

<sup>3</sup> Some fixings can be supplied by CSR Panel Systems.

## 3.2 Hebel® Wall Panel

The core component of Hebel® CIWS walls is the Hebel® wall panel. The panel is manufactured in a range of stock sizes as detailed in the Table 3.2.

**Fig. 3.1 Hebel® wall panel x-Section.**

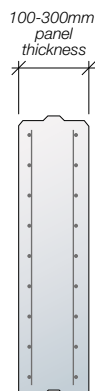

**Table 3.2 Standard & Custom manufactured panel sizes.**

Panel type	Thickness (mm)	Length (mm)	Width (mm)	Wt (kg/m <sup>2</sup> )
Standard	100	4500	600	71
	125	4500 & 5990	600	89
	150	4500 & 5990	600	107
Custom	100	Up to 4500	300 to 600	71
	125	Up to 5990	300 to 600	89
	150	Up to 5990	300 to 600	107
	175	Up to 5990	300 to 600	125
	200	Up to 5990	300 to 600	143
	225*	Up to 5990	300 to 600	160
	250*	Up to 5990	300 to 600	179
300	Up to 5990	300 to 600	214	

\* No Tongue & Groove profiles, only available in straight edge

Custom panel length and width sizes are available upon request. These are usually designed to suit wind loads and panel spans to suit project specifications, thus reducing installation time and off-cut waste. Custom panel lengths and widths can be produced to the nearest 5mm. Custom panels are subject to minimum order quantity.

## 3.3 Hebel® Mortar

**Fig. 3.2 Hebel Mortar**



Hebel® Mortar (supplied in 20kg bags) is used as thick bed mortar base to provide a level base for panel installation as well as providing acoustic and fire protection at the base of the panels.

## 3.4 Hebel® Adhesive

**Fig. 3.3 Hebel® Adhesive**



Hebel® Adhesive (supplied in 20kg bag) is used for gluing the panels together at vertical and horizontal joints.

### 3.5 Anti-corrosion Coating Agent

Steel reinforcing exposed on cut panels is to be coated with a liberal application of Fentak Dipcoat, anti-corrosion agent.



### 3.6 Hebel® Patch

Fig. 3.4 Hebel® Patch.



Minor Chips or damage to panels are to be repaired using Hebel® Patch (supplied in 10kg bags).

### 3.7 Gyprock™ Plasterboard

Hebel® CIWS walls can be lined with Gyprock™ Plasterboard on the internal side of the wall if constructing office space or other such areas of the building. The type, thickness and densities of plasterboard will be as per project specifications. Additional information on the Gyprock™ Plasterboard is available through Gyprock™.

### 3.8 External Finishes

Fig. 3.5 Hebel® HighBuild™

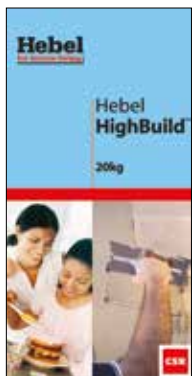

External finishes can be rendered systems or different types of coating systems. The manufacturer of the external finishes

must confirm its suitability for application on AAC products. For more information on external finishes refer to the External Finishes section in the Commercial & Industrial Wall Systems Design Guide.

Hebel® HighBuild render is the recommended product.

### 3.9 Sealant

All gaps in internal and external junctions and control joints must be filled with appropriate sealants. Sealants shall be installed in accordance with the sealant manufacturers instructions.

### 3.10 Brackets, Fasteners & Fixings

#### Hebel® Panel Brackets & Fixings

For securing Hebel® wall panels to various support structures a number of different brackets and fixings are available. These brackets & fixings are shown in Fig. 3.6 and they are:

1. Hebel® tension tie
2. Hebel® slotted angle bracket
3. Hebel® V-nails

For more information on how those brackets and fixings are used in various connection assemblies, please refer to connection details as shown in this guide.

Fig. 3.6 Hebel® brackets and fixings.



#### Other Fixings

Fixings such as those required for securing cupboards and other furnishings to Hebel® wall panels are to be specified and installed in accordance with the fixing manufacturer's instructions.

# 4.0 Delivery & Storage

## 4.1 Unloading Panel Bundles

Panel bundles shall be unloaded and moved with only approved lifting devices. Before use, the lifting devices should be checked for the required lifting tags. Panels should be unloaded as close as possible to the intended installation area. This will increase work efficiency and minimise the need for secondary lifting.

**NOTE:** Secondary handling increases the risk of panel damage. The repair of damage sustained during lifting and moving is the responsibility of the lifter. When damage is excessive, the panel must be replaced.

Fig. 4.1 Hebel® panel shipping bundle



### Unstrapping Bundles

Ensure appropriate bracing is installed to bundles prior to removal of strapping to prevent panels from falling. Panels can be held together with sash clamps, ratchet straps or Hebel® stabilising bars.

Fig. 4.2 Stacking bundles of Hebel® panel

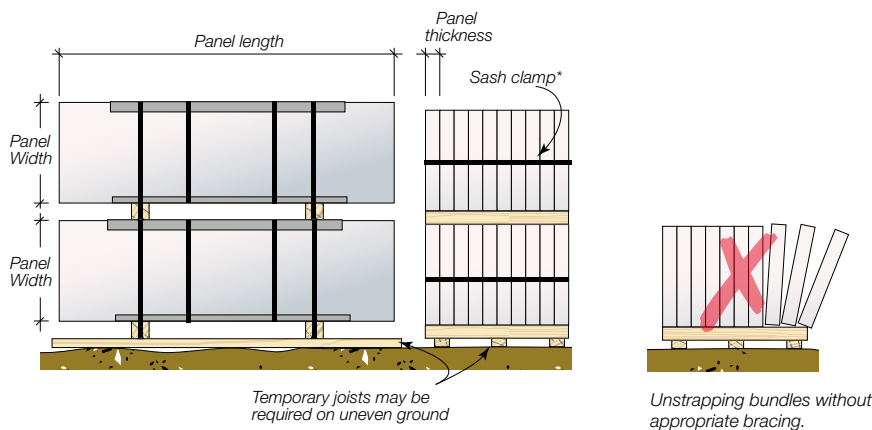

## 4.2 Storage

All materials must be kept dry and preferably stored undercover. Care should be taken to avoid sagging or damage to ends, edges and surfaces.

All Hebel® products must be stacked on edge and properly supported off the ground, on a level platform. Panel bundles can be stacked two high. The project engineer should be consulted as to the adequacy of the structure to support the stacked bundles.

If outside, Hebel® panels must be stored off the ground and protected from the weather. Only single bundles positioned on the ground can be opened. To provide a level surface, we recommend placing temporary joists beneath the supporting cleats.

# 5.0 Panel Handling

## 5.1 Manual Handling

CSR Panel Systems recommends using a trolley or other mechanical apparatus to move the panels around the work site. Manual handling where people physically move a panel should be kept to a minimum, with the weight being supported by an individual kept as small as possible. Any concerns regarding the weight to be handled should be discussed with the panel installation contractor.

To minimise the possibility of manual handling injuries, Hebel® suggests the following:

- Use mechanical aids, such as trolleys, forklifts, cranes and levers, or team lifting to move panels.
- Keep the work place clean to reduce the risk of slips, trips and falls, which can cause injury.
- Plan the sequence of installation to minimise panel movements and avoid awkward lifts.
- Train employees in good lifting techniques to minimise the risk of injury.

## 5.2 Mechanically Assisted Handling

Moving and handling Hebel® Wall Panels should be done using mechanical aids such as forklifts, cranes and special panel lifting trolleys. Different panel lift attachments are available for installing both horizontal and vertical panels (see Figures 5.1 and 5.2). For purchasing or hire of these devices please contact CSR Panel Systems.

Guidelines for handling the Hebel® Wall Panels are detailed in the "Technical Bulletin Hebel® Wall Panel Handling & Installation Guidelines, HTB799".

Fig. 5.1 Horizontal panel lift attachment.



Fig. 5.3 Vertical panel lift attachment.



## 5.3 Health, Safety & Personal Protective Equipment (PPE)

Hebel® AAC products are cement-based, which may irritate the skin, resulting in itching and occasionally a red rash. The wearing of gloves and suitable clothing to reduce abrasion and irritation of the skin is recommended when handling Hebel® AAC products.

Approved respirators (AS/NZS1715 and AS/NZ1716) and eye protection (AS1336) should be worn at all times when cutting and chasing. Refer to the Hebel® Material Safety Data Sheets (MSDS).

For further information contact CSR Panel Systems or visit the website, [hebelaustraliacom.au](http://hebelaustraliacom.au).

Fig. 5.2 Standard personal protection equipment.



## 5.4 Cutting

The use of power tools when cutting concrete products may cause dust, which contains respirable crystalline silica, with the potential to cause bronchitis, silicosis and lung cancer after repeated and prolonged exposure. When using power or hand tools, on Hebel® products, wear a P1 or P2 respirator and eye protection. When cutting, routing or chasing Hebel® products with power tools, use dust extraction equipment and wear appropriate hearing protection. Refer to the appropriate Hebel® MSDS. For further information, contact CSR Panel Systems or visit the website: [hebel.com.au](http://hebel.com.au)

Reinforcement exposed during cutting is to be coated with a liberal application of Hebel® corrosion protection paint.

# 6.0 System Installation

## 6.1 Installation of CIWS Walls

### 6.1.1 Read all specification sheets

Before commencing any installation work make sure that all the specification sheets and details have been read and understood. Make sure that you have all the required material and drawings that are necessary to do the job.

### 6.1.2 Setting out and positioning of walls

Before commencing any installation work, clean and tidy up the work area. Mark out the location of the walls, control joints, doors, windows, etc.

### 6.1.3 Control Joints

Minimum specification for control joint details must include:

- 6m maximum distance between control joints on straight wall runs.
- At all corners in walls where movement and/or expansion and contraction is possible.
- At all junctions where Hebel® wall panels abut a structure of different material.

Control joint locations and geometry must be confirmed by the building designer.

The building designer must confirm all control joint widths as the magnitudes of expected horizontal and vertical movements (deflections) might vary from project-to-project.

### 6.1.4 Installation of Steel Base Angle

The steel base angle is required in situations where the Hebel® panels are located in front of the slab or over openings. It is also required where the height of the panels exceeds more

than 6m. The angle must be installed in accordance with the project engineer's specifications and details.

### 6.1.5 Panel preparation

Hebel® Wall Panels should be sized and prepared before laying the Hebel® Mortar down or applying Hebel® Adhesive. The panels can be trimmed on-site using a circular saw equipped with diamond tipped cutting blade. All the loose AAC particles should be brushed off the panel with a rough broom. Steel reinforcement that is exposed on cut panels must be coated with a liberal application of anti-corrosion agent. Any minor damage and chips to the panels must be repaired using Hebel® Patch.

### 6.1.6 Hebel® Mortar Installation

Panels sitting on top of concrete or masonry base supports must be bedded on Hebel® Mortar.

Flashings or DPC bond breakers are used in conjunction with Hebel® Mortar. These are usually sandwiched into Hebel® Mortar or installed directly on top of the concrete or masonry supports.

The thickness of the mortar bed is approximately 10mm and should be installed across the full thickness of the wall panels. Mixing of the mortar should be done in accordance with the instructions on the bag.

**IMPORTANT:** Hebel® panels that form the base of the wall are to be installed when levelling mortar is still wet to ensure a true and flat surface. In addition, the base panels require a minimum 300mm end bearing between concrete/ steel supports.

### 6.1.7 Hebel® Wall Panel Installation

When the preparation of the wall panel is complete locate the panel into its final position using cranes and lifting devices. Then secure the panel to the support structure with an appropriate type of fixings and brackets. When the panel is secured in place apply Hebel® Adhesive to

the panel edge where the next wall panel is to be installed. Repeat the installation process until the wall is complete.

### 6.1.8 Hebel® Adhesive Application

Hebel® Adhesive is applied to the panel with a trowel. When the panels are pushed together the joints are to be 2-3mm thick. Sufficient pressure must be applied to the panels when gluing to ensure the adhesive is fully bedded across the joint. Scrape off any excess adhesive protruding from the joints once the wall is installed. Adhesive is to be mixed to the proportions and consistency as per the instructions on the bag.

### 6.1.9 Installation of Sealants

All control joints and other gaps should be sealed off and finished neatly with fire and acoustic rated sealants. Installation of sealants must be carried out in accordance with the manufacturer's specifications. This must be done before the application of coating finishes or secondary framing and plasterboard.

### 6.1.10 Gyprock™ Plasterboard

If required, plasterboard can be installed directly on to the wall panels or secondary framing structure like steel studs and battens.

Handling and installation guidelines and additional information on the Gyprock™ Plasterboard is available through Gyprock™.

### 6.1.11 Installation of Penetrations, Electrical, Plumbing and Other Services

Installation of services and penetrations into Hebel® CIWS walls should be carried out at an appropriate construction sequence. This will allow easy access to cavities, steel framed elements and Hebel® panels, where services can be easily installed and neatly hidden.

Hebel® suggests the most appropriate time to carry out plumbing and cabling works be confirmed by the builder or



project manager on a project-by-project basis.

Suitable flexible sealants (where required) plus a neat finish for all chasings and penetrations is necessary to maintain the acoustic and fire integrity of the wall.

### 6.1.12 Application of Coating Finishes

All coating must be applied in accordance with the manufacturer’s specifications. For more information on coatings and coating requirements see the Hebel® High

Performance Coating Systems Brochure. This is available from our website: [hebel.com.au](http://hebel.com.au)

### 6.1.12 Installation of Fasteners & Fixings

All non-Hebel® fixings and fasteners such as those used for attaching shelves and furnishing should be installed in accordance with the manufacturers specifications.

All brackets and fixings used for securing Hebel® Wall Panels to the support structure should be specified by the

project engineer. Installation of these brackets & fixing to be in accordance with the manufacturer’s or project engineer’s instructions.

The Hebel® Fixing Guide available as part of the Hebel® Technical Manual should be used as a reference for approved fixings to AAC. This is available from our website: [hebel.com.au](http://hebel.com.au)

## 6.2 System Installation Sequence

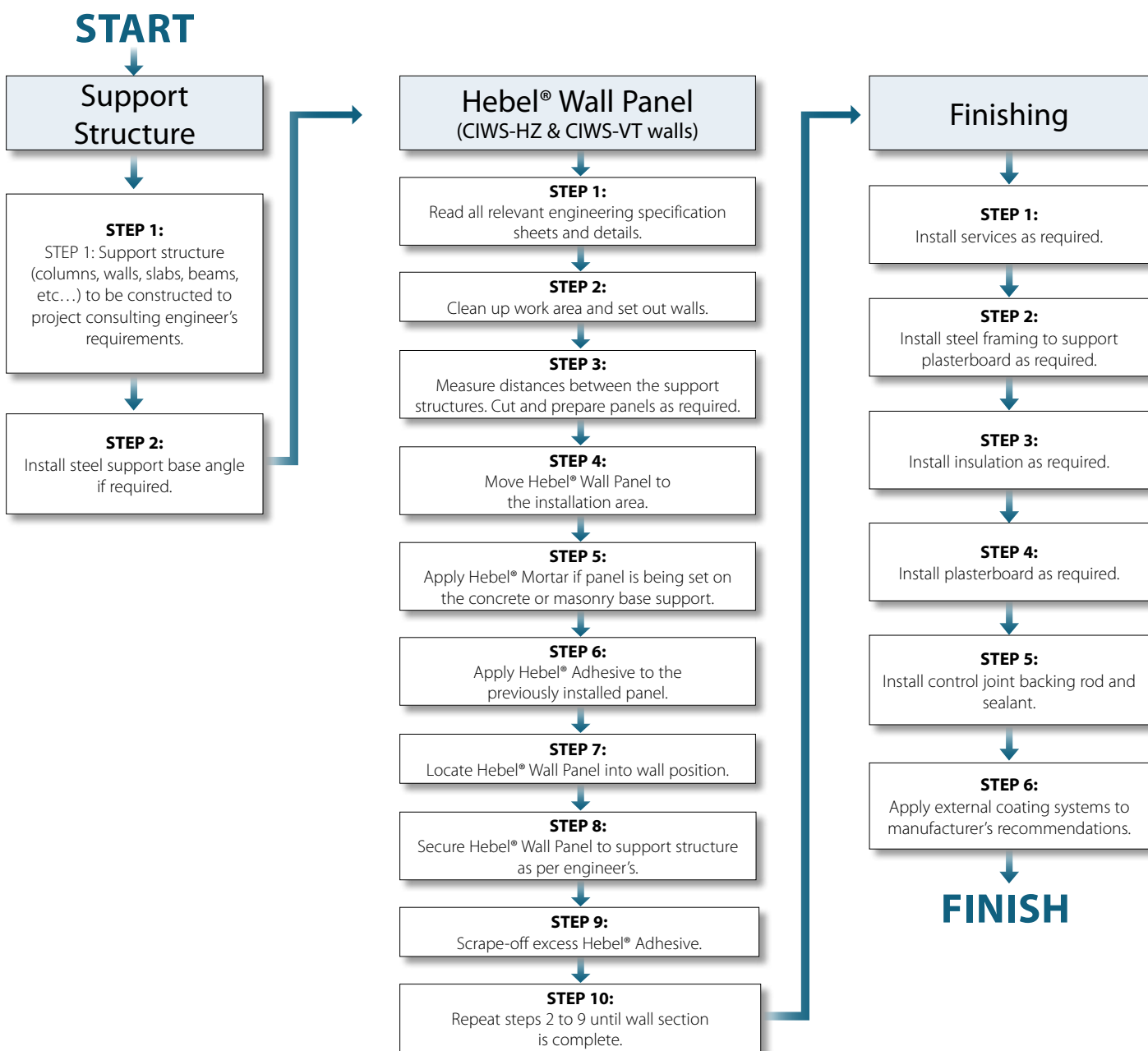

# 7.0 Construction Details- Horizontal Panels

## 7.1 Horizontal Wall Panels - Isometric, Plan & Elevation Views

Detail 7.1 Horizontal wall panels - isometric view.

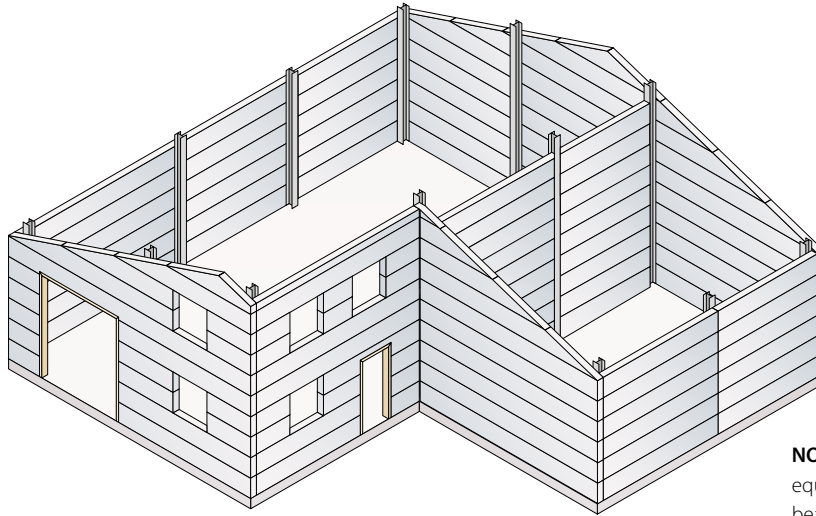

**NOTE:** Hebel® wall panels can be installed to a height equivalent to 10 full panel widths before additional bearing plates are required for higher up panels.

## 7.2 Horizontal Wall Panels - Connections and Junction Table

Table 7.1 Connection capacities in wall panels with AAC characteristic compressive strength,  $f'c = 4.0 \text{ MPa}$

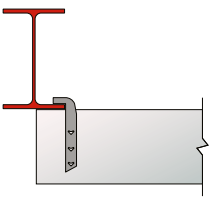
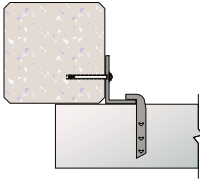
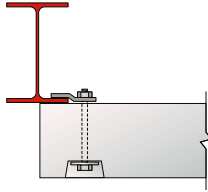
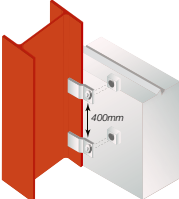
Connection Type	Connection Detail	Panel Thickness 'T' (mm)	Design Ultimate Load (kN)	Minimum Edge/End Distance (mm)
A		125	1.40	80
		≥150	2.70	80
A		125	1.40	80
		≥150	2.70	80
C		≥125	4.75	80
2C		≥125	9.50	80

# 7.3 Horizontal Wall Panels - Connection and Junction Details

**Detail 7.3.1 Horizontal wall panel & concrete/masonry base support detail (elevation).**

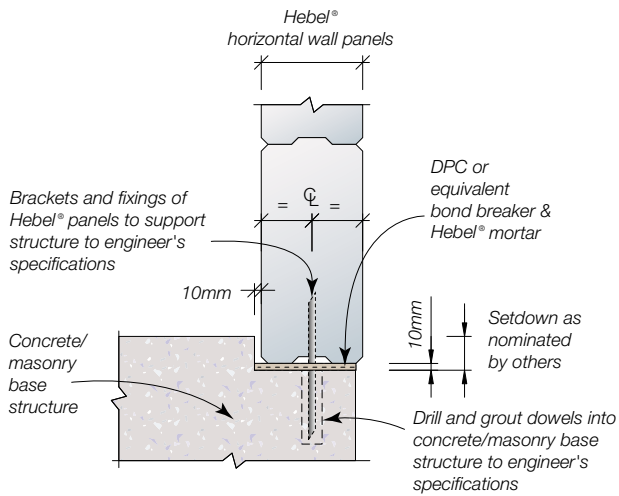

**Detail 7.3.2 Horizontal wall panel & steel base support detail (elevation).**

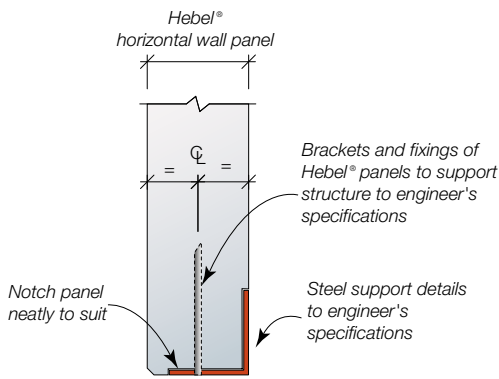

**Detail 7.3.3 Horizontal wall panels control joint detail (plan).**

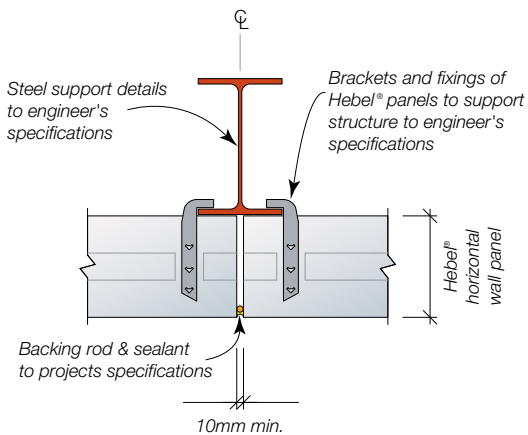

**Detail 7.3.4 Horizontal wall panel & steel support - corner detail (plan).**

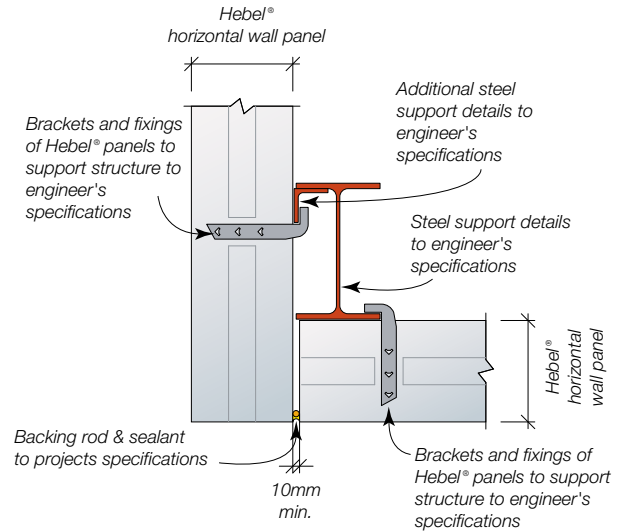

**Detail 7.3.5 Horizontal wall panel & concrete/masonry support - Tension Tie (plan).**

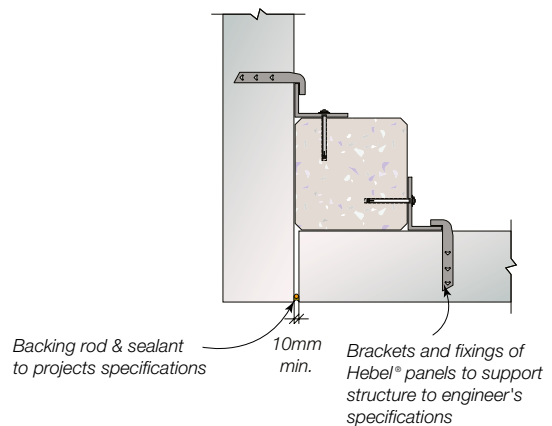

**Detail 7.3.6 Horizontal wall panel & concrete/masonry support - Bottled Z Clip (plan).**

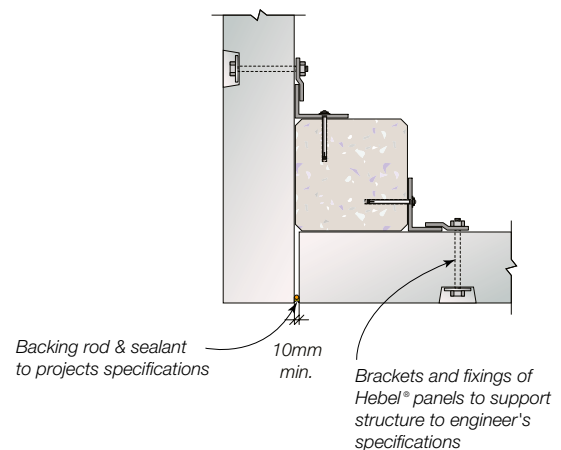

**Detail 7.3.7 Horizontal wall panel & steel support - panel end detail (plan).**

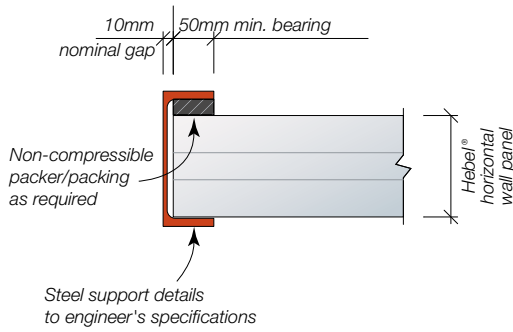

**Detail 7.3.10 Horizontal wall panel & concrete/masonry support detail- Bolted Z Clip (plan).**

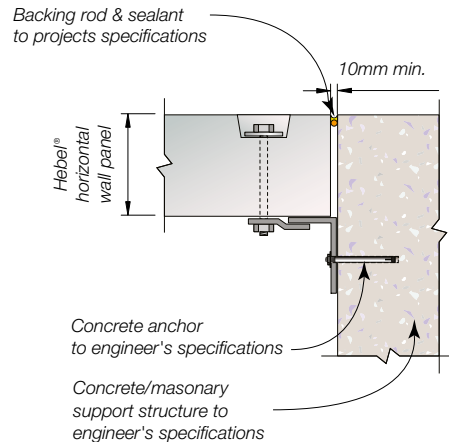

**Detail 7.3.8 Horizontal wall panel & steel support - panel end detail (plan).**

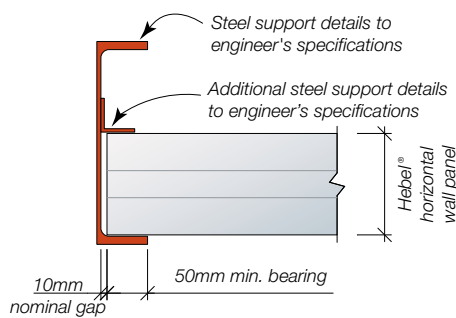

**Detail 7.3.11 Horizontal wall panel & roof/top of wall detail (elevation).**

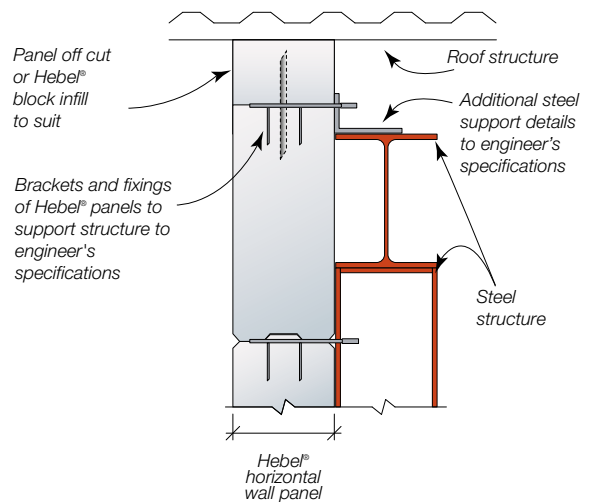

**Detail 7.3.9 Horizontal wall panel & concrete/masonry support - Tension Tie (plan).**

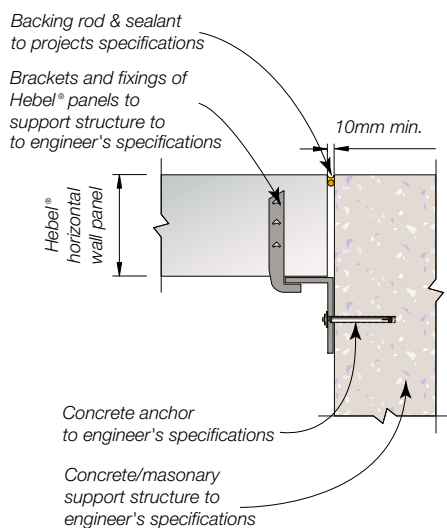

# 7.4 Horizontal Wall Panels - Opening Details

Detail 7.4.1 Single panel width opening.

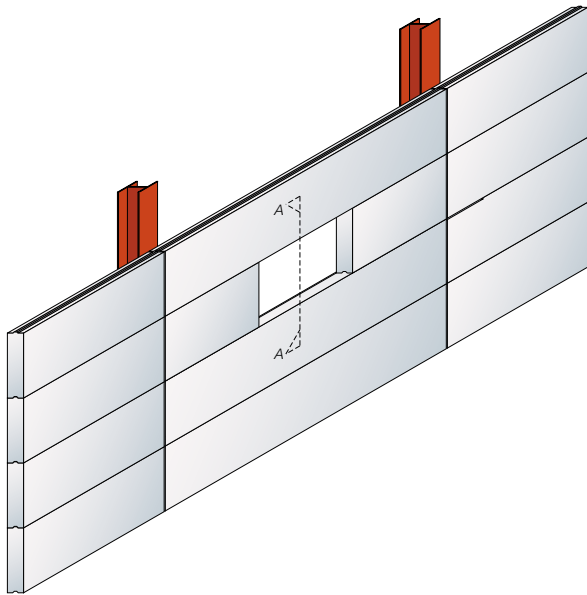

Isometric View

**NOTE**

Panels above and below opening to support wind loads shed from opening & infill panels.

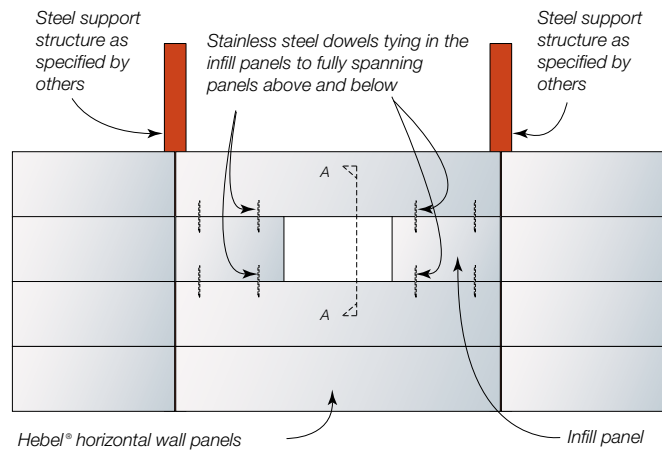

Elevation View

Detail 7.4.2 Single panel width opening - Section "AA" detail.

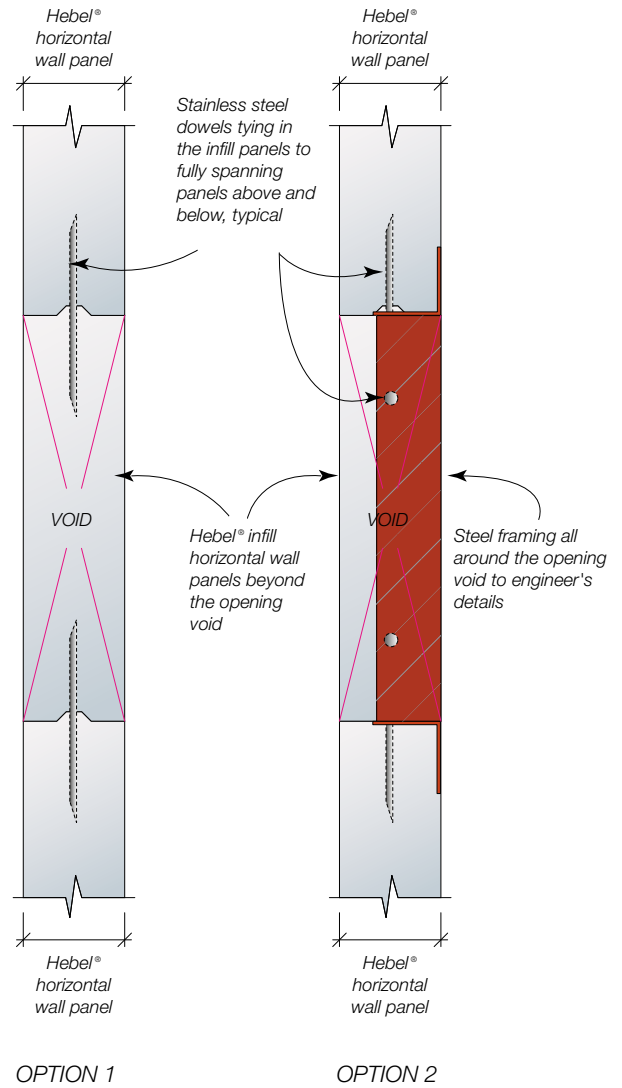

Detail 7.4.3 Multiple panel width opening.

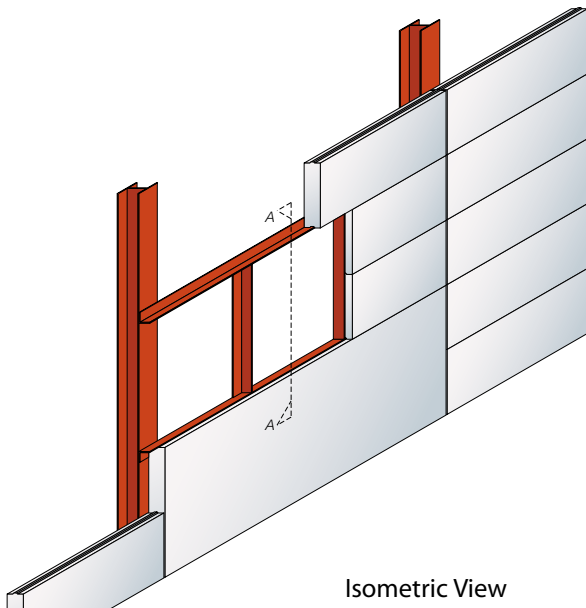

Detail 7.4.5 Multiple panel width opening - Section A-A detail.

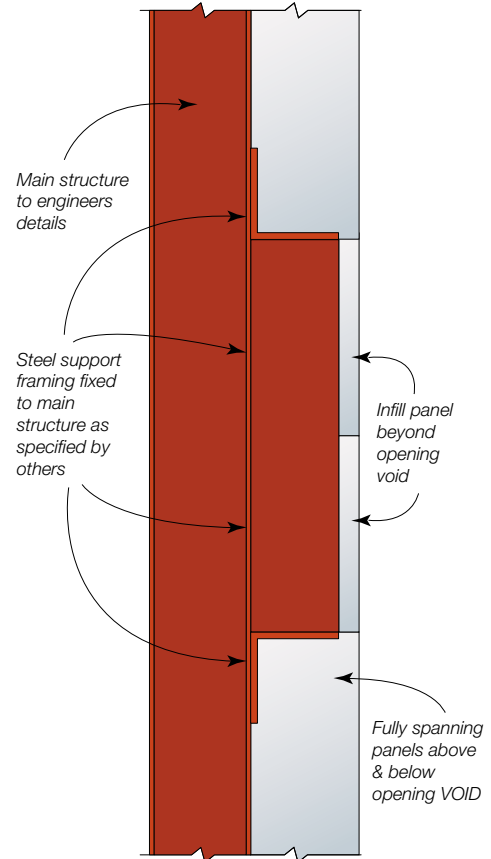

Detail 7.4.4 Multiple panel width opening - elevation detail.

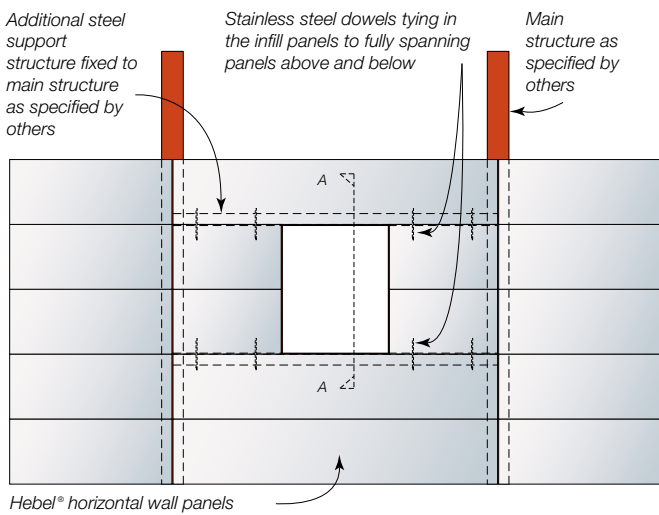

**NOTE**

Additional steel support structure to transfer loads from opening & infill panels to main structure. Additional steel support structure to be specified by others.

Detail 7.4.6 Multiple panel width opening - sample door opening isometric detail.

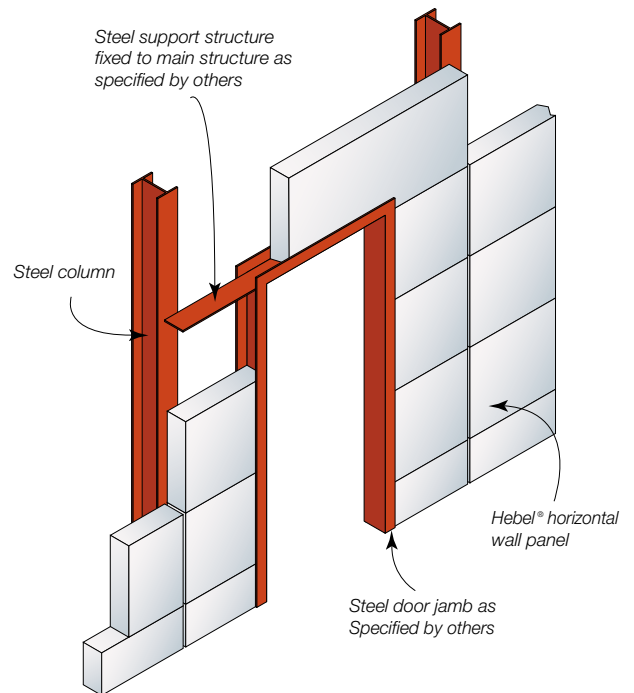

# 8.0 Construction Details - Vertical Panels

## 8.1 Vertical Wall Panels - Isometric, Plan & Elevation Views

Detail 8.1.1 Vertical wall panels - isometric view

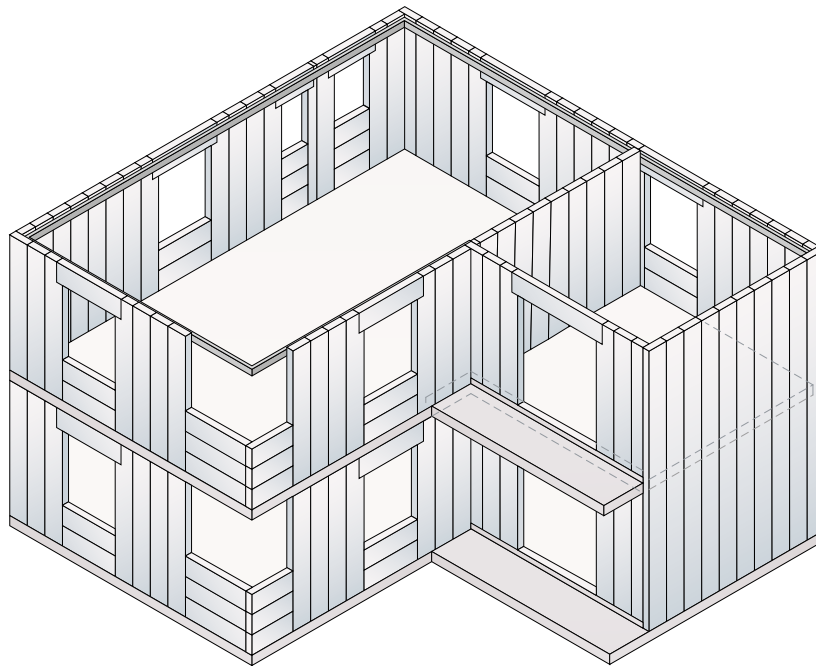

## 8.2 Vertical Wall Panels - Connections and Junction Details

Table 8.2.1 Connection capacities in wall panels with AAC characteristic compressive strength,  $f'c = 4.0 \text{ MPa}$

Connection Type	Connection Detail	Panel Thickness 'T' (mm)	Design Ultimate Load (kN)
B option 1 - Top Connection		125	0.68
		$\geq 150$	1
B option 1 - Bottom Connection		125	0.68
		$\geq 150$	1
B option 2 - Top Connection		100	0.8
B option 2 - Bottom Connection		100	0.8

**Table 8.2.1 Connection capacities in wall panels with AAC characteristic compressive strength,  $f'c = 4.0$  MPa (continued)**

Connection Type	Connection Detail	Panel Thickness 'T' (mm)	Design Ultimate Load (kN)	Minimum Edge/End Distance (mm)
C		≥125	4.75	80
C		≥125	4.75	80
C		≥125	4.75	80
2C		≥125	9.50	80



# 8.3 Vertical Wall Panels - External Junction Details

Detail 8.3.1 Z clip details.

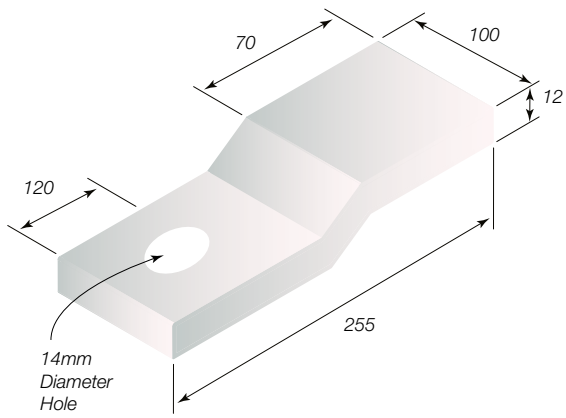

Detail 8.3.3 Vertical wall panel & concrete/masonry structure top of wall detail (elevation).

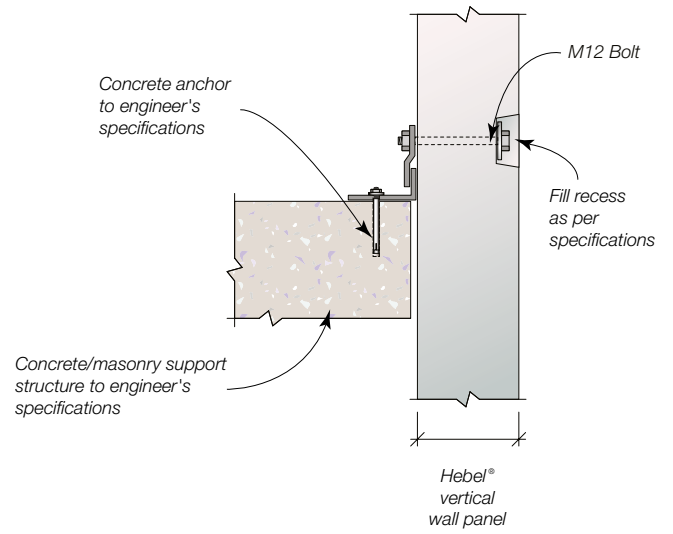

Detail 8.3.2 Vertical wall panel & concrete/masonry structure base detail (elevation).

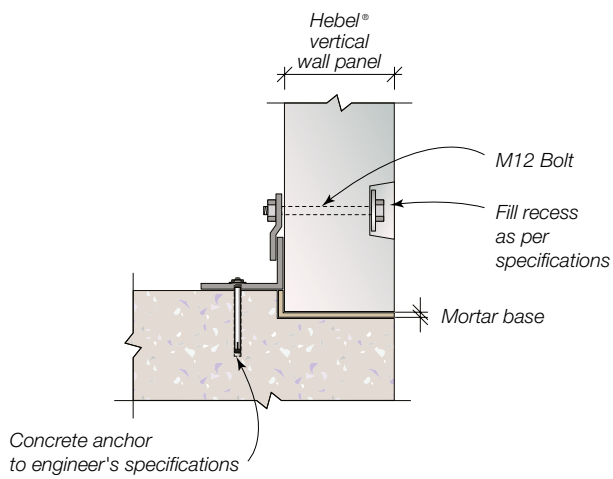

Detail 8.3.4 Vertical wall panel & roof structure detail (elevation).

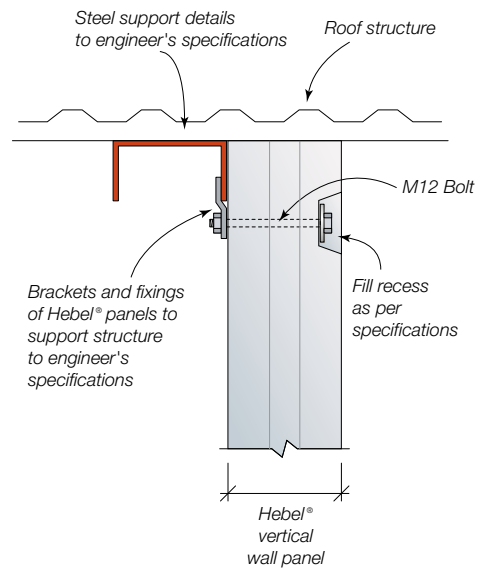

**Detail 8.3.5 Vertical wall panel top connection detail (elevation).**

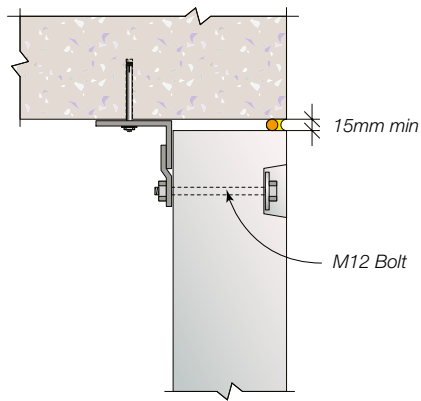

**Detail 8.3.7 Vertical wall panel control joint detail (plan).**

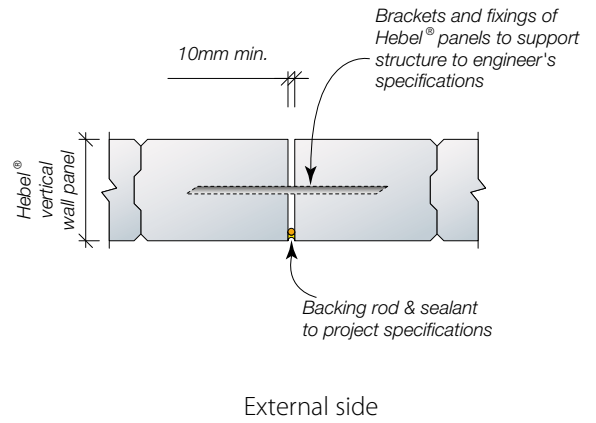

**Detail 8.3.6 Vertical wall panel corner detail (plan).**

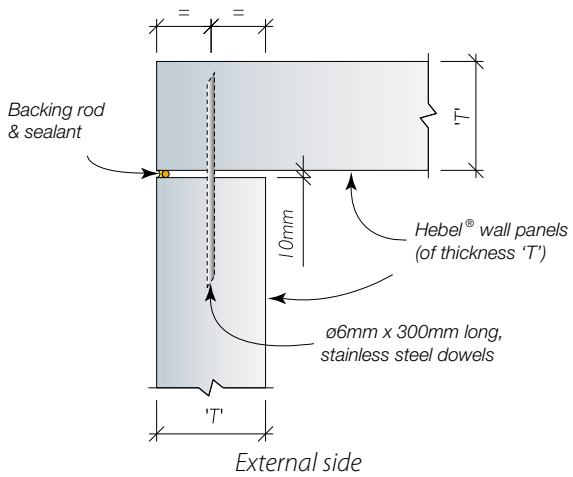

# 8.4 Vertical Wall Panels - Internal Junction Details

**Detail 8.4.1 Head detail for panels  $\geq 125$ mm thick (elevation)**

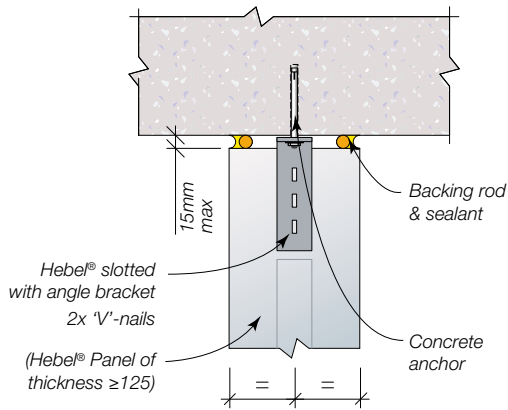

**Detail 8.4.3 Head detail for 100mm Panel (elevation)**

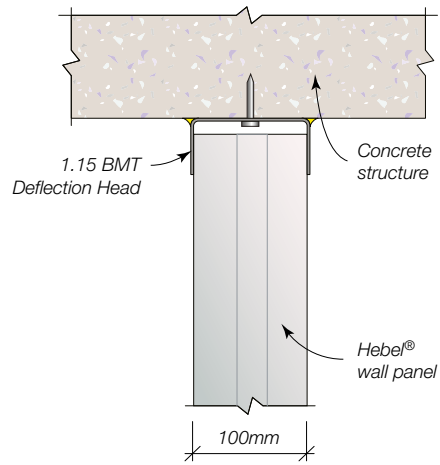

**Detail 8.4.2 Base detail for Panels  $\geq 125$ mm thick (elevation)**

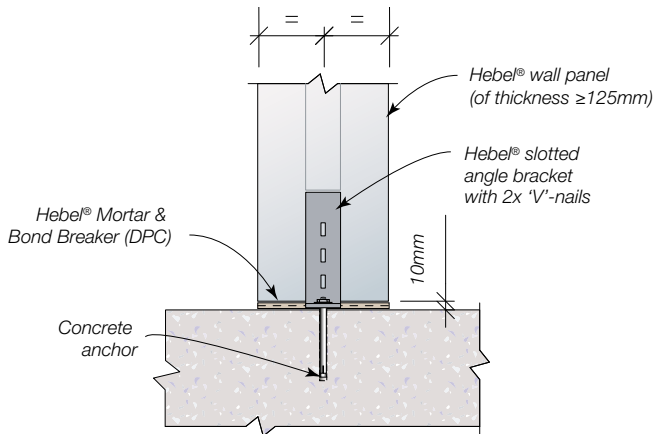

**Detail 8.4.4 Base Angle for 100mm Panel (elevation)**

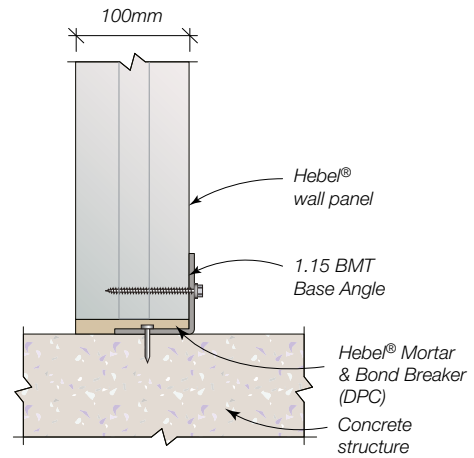

# 8.5 Vertical Wall Panels - Opening Details

Detail 8.5.1 Multiple panel width opening detail 1.

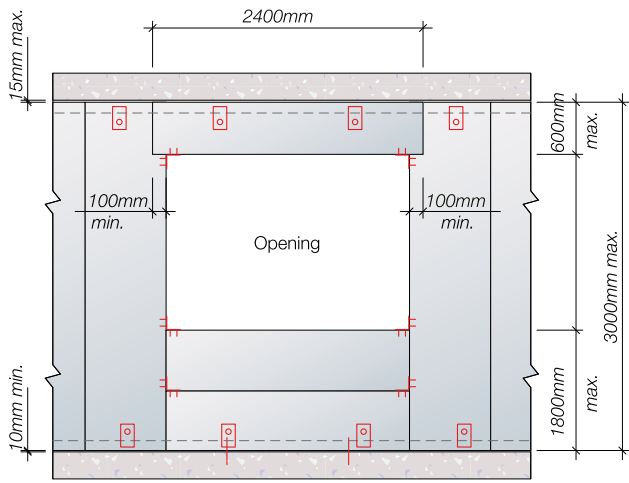

Detail 8.5.3 Multiple panel width opening Section A-A detail.

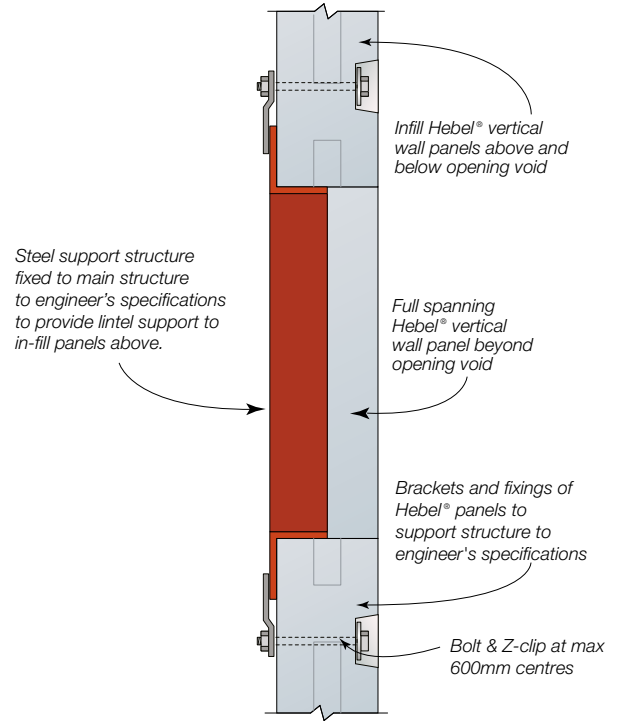

Detail 8.5.2 Multiple panel width opening detail 2.

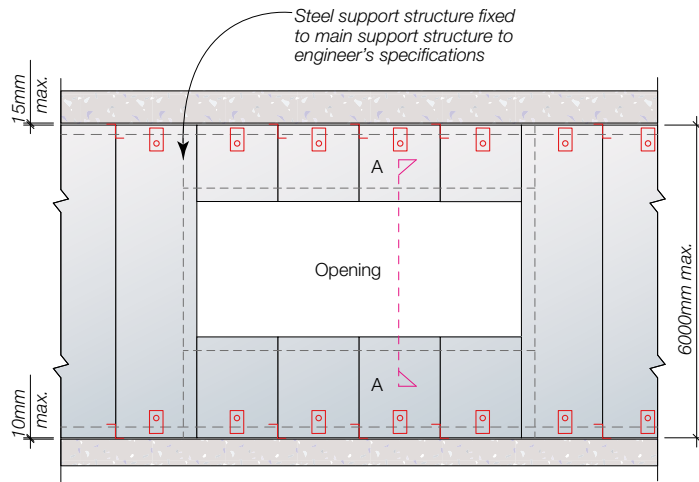

# 9.0 Penetration Details

## Detail 9.1 Horizontal and vertical wall panels penetration positioning and sizing detail

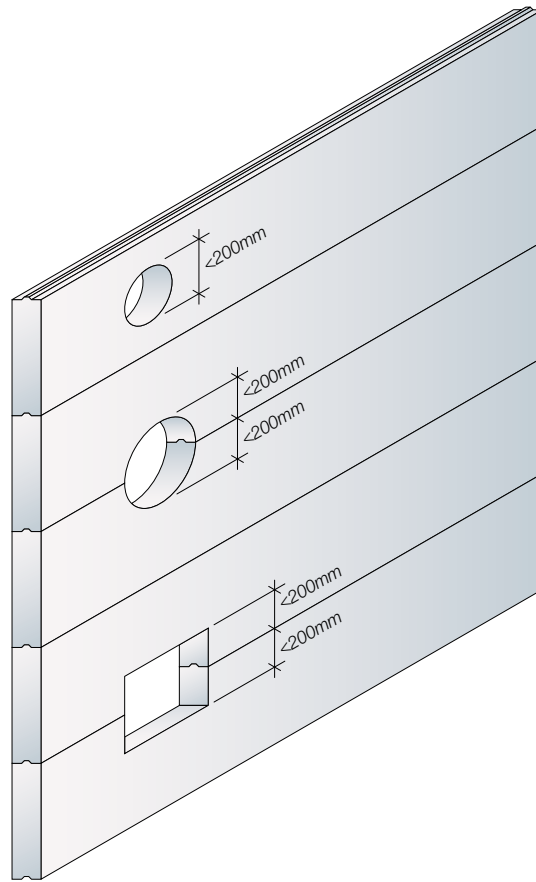

### NOTE

- 1) Width of the opening to be less than one third of panel width, to be cut on site.  
All panels shown are 600mm wide.
- 2) Notch should not be overcut as additional reinforcement could be cut which would reduce the panel's performance.

## Detail 9.2 Horizontal & vertical wall panels - multiple penetration layout detail.

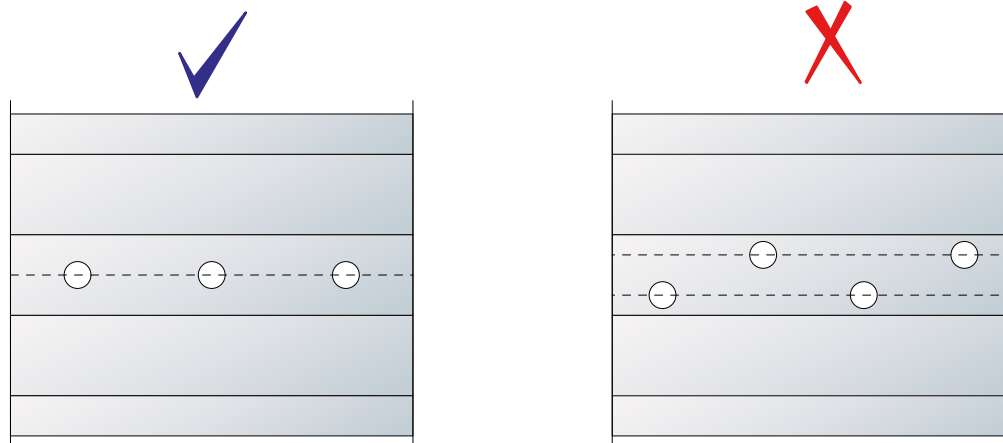

### NOTE

Where penetrations do not align, contact CSR Hebel Engineering Services for advice

# Appendix A - Installation Checklist

This checklist is to be read in conjunction with ALL Hebel® documentation including the Hebel® Technical Manual, Hebel® Commercial and Industrial Wall Systems Design Guide, Hebel® Commercial and Industrial Wall Systems Installation Guide, Safe Work Method Statements (SWMS) and technical advice from Hebel®. Co-ordination and compliance with specifications by the project engineers (acoustic, fire, thermal and structural), and architect is also compulsory. These project consultants are also responsible for incorporating this system into the subject project. If you are not in receipt of any of these documents, please ask your Hebel® representative or project consultant to provide them prior to commencement of any Hebel® System installation.

<b>Project:</b>			
<b>Builder:</b>			
<b>Hebel® Installer:</b>			
<b>Building:</b>			
<b>Floor Level:</b>			
<b>Grids or Area:</b>			
	CONSTRUCTION STEP	SATISFACTORY	ACTION REQUIRED
<b>Before commencing CIWS Wall Installation:</b>			
1.1	Has all the documentation and specification sheets been supplied for the construction of the project?		
1.2	Have all the specified wall panels been supplied (length, width and thickness)?		
1.3	Have all the required fixing components been supplied (brackets and fixings)?		
1.4	Is all of the panel handling equipment on site?		
1.5	Have all the panels been supplied in good condition without major panel damage?		
1.6	Has all the support structure been constructed?		
1.7	Has the additional support angles and structure been installed?		
1.8	Is all support structure position within tolerances?		
<b>During the Installation of Hebel Wall Panels</b>			
2.1	Is the panel orientation correct (compared with layout drawings/specs)?		
2.2	Are the correct connections types being used and at the right wall junctions?		
2.3	Have all the required fixing components been supplied (brackets and fixings)?		
2.4	Is the base of the panel sitting correctly in accordance with specifications?		
2.5	Has the anti- corrosion coating been applied to cut and exposed reinforcement?		

2.6	Are joints between CSR Hebel® wall panels fully glued with Hebel® Adhesive?		
2.7	Are panel joints 2 – 3 mm thick and any excess Hebel® Adhesive removed?		
<b>Finishing of the Hebel Wall Panel Installation</b>			
3.1	Have minor panel damages been patched over in accordance with patching procedures and guidelines?		
3.2	Have the control joints been caulked with appropriate sealant and in accordance with the manufacturer’s recommendations?		
3.3	Have all the penetrations been installed correctly ( ie are the penetrations <1/3 of the panel width, do they have enough gap to allow for movement and is the gap sealed with appropriate sealant) ?		
3.4	Have the internal lining materials installed in accordance with project specifications?		
3.5	Has the external coating been applied in accordance with manufacturer’s recommendations and project consultants’ instructions?		
3.6	Has the internal coating been applied in accordance with manufacturer’s recommendations and project consultants’ instructions?		
<b>ALL ITEMS LISTED ABOVE HAVE BEEN COMPLETED SATISFACTORILY AND TO AN ACCEPTABLE LEVEL FOR THE FOLLOWING CONTRACTOR.</b>			
	<b>HEBEL® INSTALLER</b>	Signature	
	Name		
	Date		



**The better way to build**

#### CSR HEBEL

Trinity 3, 39 Delhi Road  
North Ryde NSW 2113, Australia  
Telephone +61 2 9235 8000

## The better way to build

Hebel is a quality building product, and is backed by CSR Building Products Limited.

For more information visit our website.

[www.hebel.com.au](http://www.hebel.com.au)

For sales enquiries or further information, please telephone us from anywhere in Australia:

**1300 369 448**

### Health and safety

Information on any known health risks of our products and how to handle them safely is on product packaging and / or the accompanying documentation.

Additional information is listed in the Material Safety Data Sheet (MSDS). To obtain a copy of a MSDS, download from [www.hebel.com.au](http://www.hebel.com.au). Contractors are required by law to perform their own risk assessments before undertaking work.

### Performance and certification

Hebel® products and systems are developed in Australia by CSR Building Products. ABN. 55 008 631 356. It is a manufacturer and supplier of Hebel Autoclaved Aerated Concrete (AAC) products. Because it is a manufacturer and supplier only, CSR does not employ people qualified as Accredited or Principal Certifiers.

CSR is therefore unable to provide Construction Compliance Certificates or Statements of Compliance. CSR conducts appropriate testing of its products and systems to determine performance levels. These include structural, fire and acoustic tests. Testing is conducted and certified by appropriate specialists in these fields. When using Hebel products and systems in specific projects, such specialists should be consulted to ensure compliance with the Building Code of Australia and relevant Australian Standards.

### Disclaimer

Information presented in this document is supplied in good faith and to the best of our knowledge was accurate at the time of preparation. The provision of this information should not be construed as a recommendation to use any of our products in violation of any patent rights or in breach of any statute or regulation. Users are advised to make their own determination as to the suitability of this information in relation to their particular purpose or specific circumstances. Since the information contained in this document may be applied under conditions beyond our control, no responsibility can be accepted by CSR, or its staff for any loss or damage caused by any person acting or refraining from action as a result of misuse of this information.

### Other

The design of a wall, floor or fence system requires the services of professional consultants. This document has been prepared as a source of information to provide general guidance to those consultants – and in no way replaces the services of the professional consultant and relevant engineers designing the project.

No liability can therefore be accepted by CSR or other parties for the use of this document. Hebel products and systems undergo constant research and development to integrate new technology and reflect ongoing performance enhancement.

Hebel systems are constantly reviewed so as to reflect any changes in legislative building requirements and or general developments in common building practice, due to our commitment to continual development and improving our building systems.

We advise that all users of this document should regularly check that this document is current, and they are applying our latest design information.

The latest editions of our documents are available on our website: [www.hebel.com.au](http://www.hebel.com.au)

### HELIT036 October 2015

#### Available from: