

The logo for hebel, featuring the word "hebel" in a white, lowercase, sans-serif font. To the right of the text is a stylized graphic element consisting of a series of small, square perforations arranged in a grid, followed by a solid grey trapezoidal shape pointing to the right.

The better way to build

High Rise Apartments Student Accommodation Hotels and Commercial Facades & Balcony Blades

DESIGN AND
INSTALLATION GUIDE

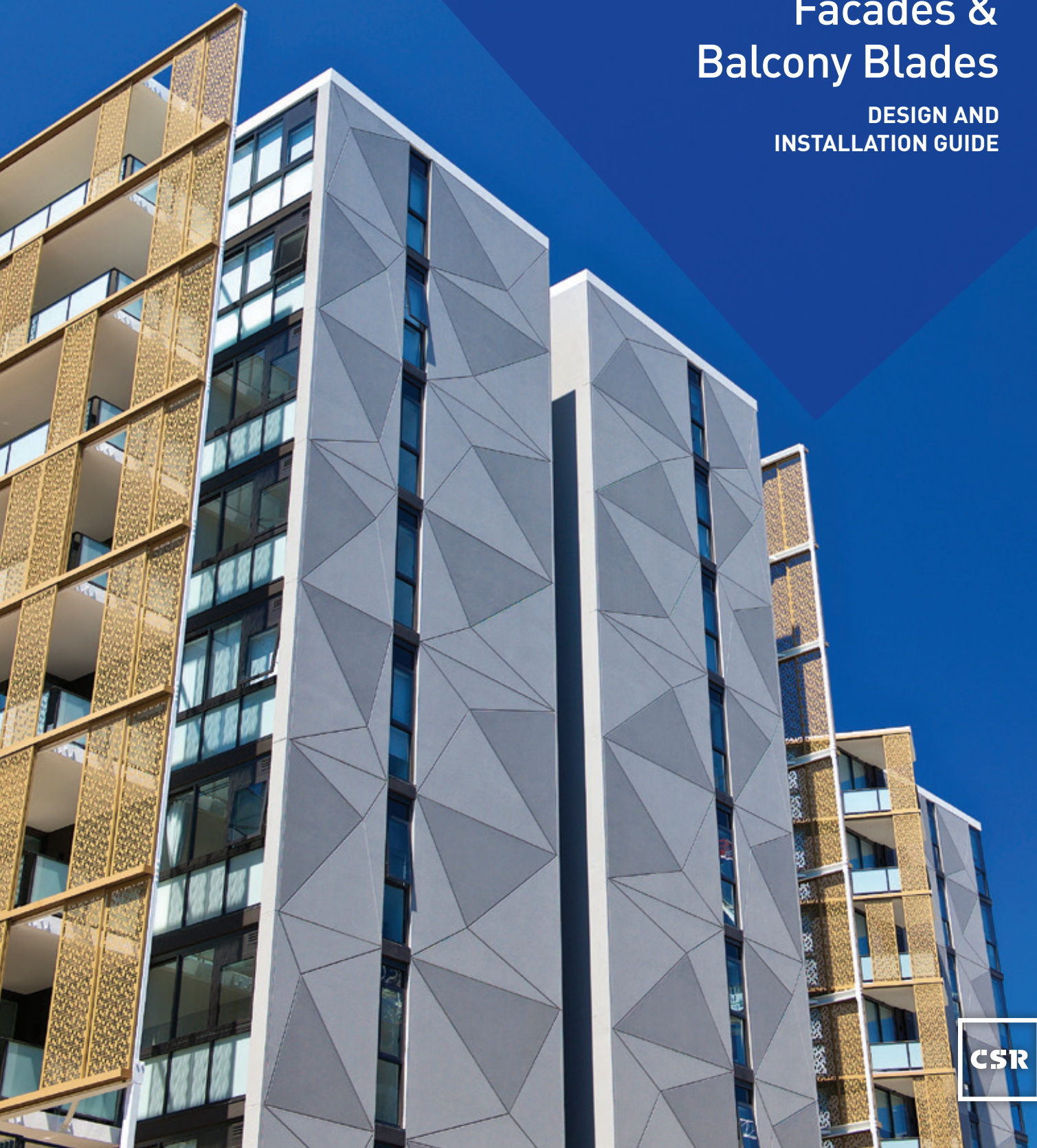

CSR

This Design and Installation Guide has been prepared as a source of information to provide general guidance to consultants – and in no way replaces the services of the professional consultant and relevant engineers designing the project.

When preparing this document the most up-to-date standards and codes were used. However CSR Hebel cannot guarantee that these standards and codes are currently used or applicable in your state or territory.

It is the responsibility of the architectural designer and engineering parties to ensure that the details in this Design and Installation Guide are appropriate for the intended application.

The recommendations of this guide are formulated along the lines of good building practice, but are not intended to be an exhaustive statement of all relevant data.

Introduction	1
1. Design and selection detail	
1.1 Applications overview	2
1.2 Facade hidden slab edge	4
1.3 Facade visible slab edge	6
1.4 Breezeway	8
1.5 Balcony Blade	9
1.6 System design	10
1.7 Design and detailing considerations	11
1.8 System components	14
2. System performance	18
2.1 Structural provisions	18
2.2 Fire resistance performance	23
2.3 Weathertightness	25
2.4 Finishes	26
2.4.1 Coating	26
2.4.2 Supplementary cladding over hebel facade	27
2.4.3 PowerPattern™ panels	28
2.5 Acoustic performance	29
2.6 Energy efficiency	30
2.7 Durability	33
3. Installation detail	34
3.1 Installation sequence: facade with visible slab edge	34
3.2 Installation sequence: facade with hidden slab edge	37
3.3 Installation	40
3.4 Construction details overview	43
3.5 Construction details	44
3.5.1 Visible and hidden slab edge	44
3.5.2 Stud frame, wall wrap and panel installation	45
3.5.3 Vertical junctions	48
3.5.4 Windows and doors	50
3.5.5 Balconies	52
3.5.6 Balcony blade walls	53
3.5.7 Additional details	55
4. Responsibilities	56
4.1 Construction details – Additional details	56
5. Delivery, storage and handling	58
5.1 Delivery and storage	58
5.2 Panel handling	59
6. Appendix	60
6.1 Appendix 1 Hebel PowerPanel material properties	60

BETTER BUILDINGS ARE CONSTRUCTED WITH HEBEL

HEBEL IS A LIGHTWEIGHT STEEL REINFORCED AUTOCLAVE AERATED CONCRETE (AAC) THAT HAS BEEN USED IN EUROPE FOR OVER 70 YEARS AND HERE IN AUSTRALIA FOR OVER 20 YEARS.

Hebel. A high-performance lightweight concrete panel system

Hebel is the innovative and sustainable, high-performance and lightweight steel reinforced panel system that provides total design flexibility so you can build the design you want, the way you want.

Added to this Hebel Facade system is the pressure equalised system making this facade system inherently robust from a weatherproofing viewpoint. They easily meet BCA requirements being extremely fire-resistant, have thermal absorbing properties and acoustic compliance surety.

Create the look you want

With a choice of PowerPanel and PowerPattern panels you can create the look you want. Hebel PowerPanel has a plain surface for an all-over flat finish. The Hebel PowerPattern™ range introduces a collection of patterns pre-routed onto the Hebel panels offering unparalleled design flexibility. The range comprises of four design collections. Modular in design and intended to work with the other panels in the collection.



PowerPattern Geometric



PowerPanel – Builder/ Developer: Casumo Constructions; Architect: BD Architecture

A highly efficient and modular building system that reduces your total cost to build

Hebel systems require smaller crews and their speed of installation (with less reliance on bricklaying trades) assists in reducing your overall building costs and maximising your construction efficiencies. These cost reductions can be further improved if you construct your internal walls by also using Hebel.

With minimal component use and reduced need for cranes, along with continuity of on-site trades and lower wastage, building with Hebel will reduce your overall cost to build.

Proven in the market and backed by CSR

Hebel products and systems are developed in Australia by CSR Building Products Limited. With CSR you can depend on the product quality, technical expertise, warranty and stock supplies of Hebel products and systems.

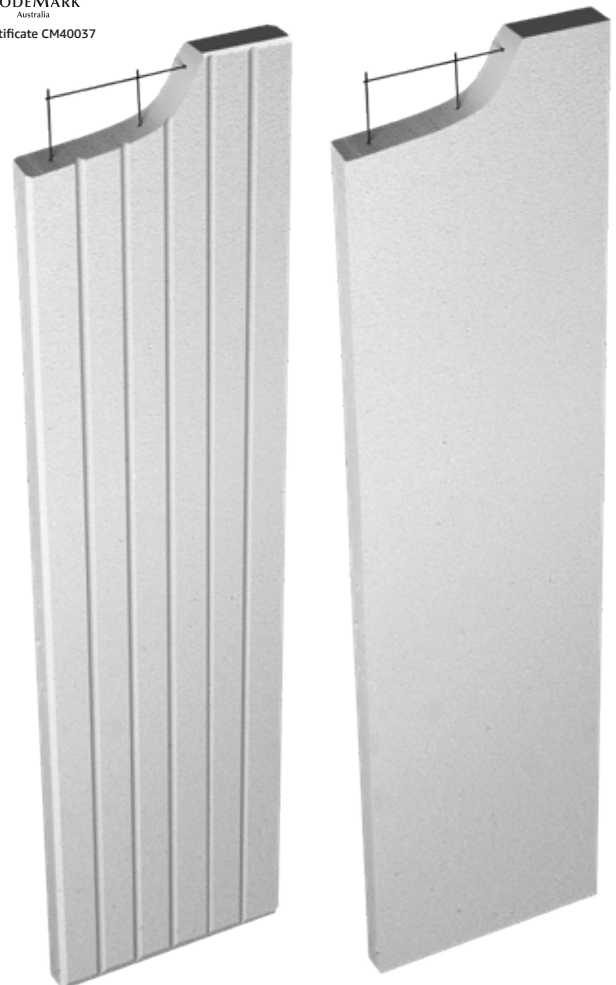

PowerPattern Lineal

PowerPanel

1.1 APPLICATIONS OVERVIEW



External facade and Breezeway walls

Hebel PowerPanel is used for external facade and breezeway corridor walls. This lightweight system provides substantial cost savings compared to traditional masonry.



Balcony blade walls

Hebel PowerPanel is used for separating walls between balconies of different sole occupancy units.



Intertenancy wall - dry to dry / wet

Designed for concealed services on one side using lightweight steel-reinforced PowerPanel, these Hebel Intertenancy Wall Systems provide a solid secure wall that maximises floor space, minimises costs and risks and delivers long-term value.



Intertenancy wall - dry / wet to dry / wet

These Hebel Intertenancy Wall Systems are the ideal solution where there are concealed services on both sides including large services applications such as shower mixers in both apartments. This quality solution using solid and secure PowerPanel maximises floor space and minimises risks and costs.



Corridor wall

Hebel Corridor Wall Systems maximise floor space and provide a solid secure wall for services located on one side between common areas and apartments.



Shaft wall - dry areas

Robust and proven Hebel Shaft Wall Systems provide a solid, secure wall with a narrow width around service shafts to dry habitable areas and between scissor stairs. Uses Hebel PowerPanel to maximise space utilisation and minimise risks and costs in high rise and multi-residential construction.



Shaft wall - wet areas

Hebel Shaft Wall Systems are designed for general partitions between service shafts and wet areas or shafts adjacent to common areas. Constructed with Hebel PowerPanel to maximise floor space and minimise risks and costs.



Service wall - plant rooms

Single mesh or caged Hebel PowerPanel is used in the Hebel Service Wall Systems to isolate and secure plant rooms from other areas of the building. For tall shaft risers with fire ratings up to 2 hours, PowerPanel can be installed horizontally to an unlimited height without the need for thin bed adhesive at the panel joints. Solid and secure, these systems maximise floor space and minimise costs and risks.

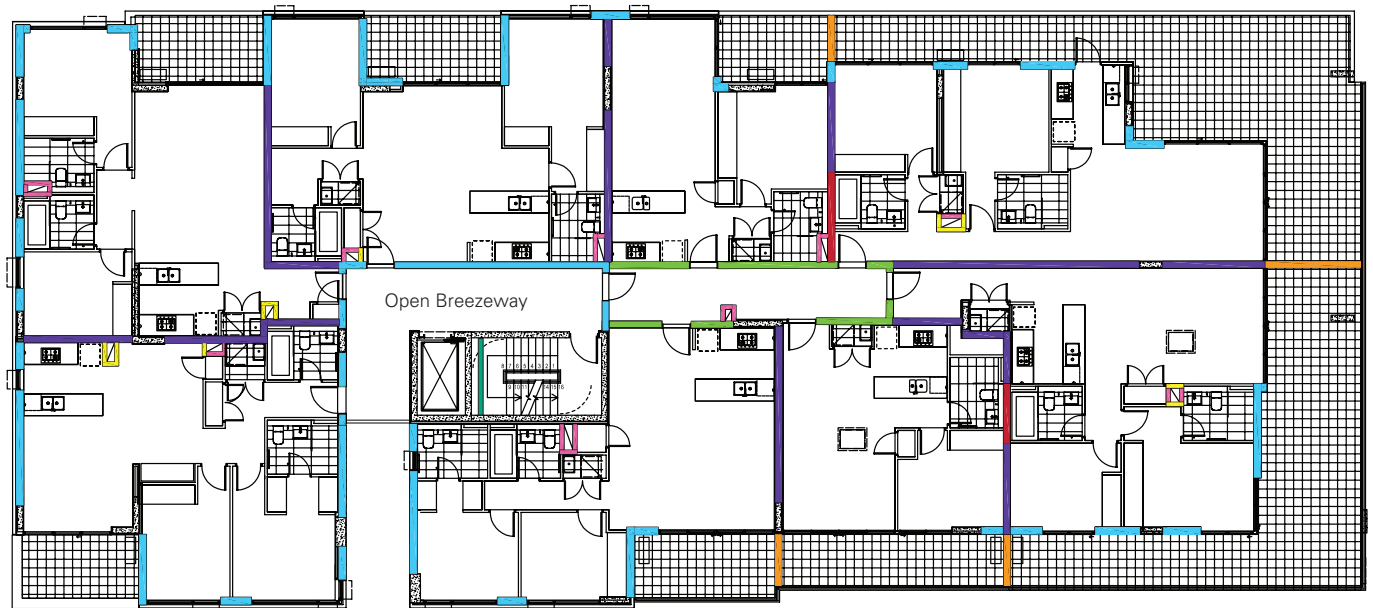

OVERVIEW OF THE HEBEL POWERPANEL SYSTEM FOR FACADES

Hebel Facades

Hebel PowerPanel Systems for Facades are non-loadbearing external wall solutions. These wall configurations consist of a Hebel PowerPanel secured to a lightweight structural (cold formed) steel support framing. The Systems suit applications ranging from low-rise industrial/commercial developments to high-rise office or medium density residential buildings.

The Hebel PowerPanel Systems for Facade have been developed for framed construction following the principles of pressure equalisation. Pressure equalisation refers to the wall cavity being allowed to experience the same pressure as that acting on the outside wall.

The system comprises an external rain screen and an internal air seal. The internal air seal is dry and not exposed to the atmosphere or UV light energy, so sealants have the best opportunity to perform well over a long design life. On the external surface, the weather tightness of the Facade does not rely on the integrity of coatings and sealants as there is no pressure differential. This prevents water from being sucked into the cavity, even if there are minor holes or imperfections in the sealant.

Hebel PowerPanel Systems for Facades are divided into two systems: a Visible Slab Edge (Hebel1349) and a Hidden Slab Edge (Hebel1347).

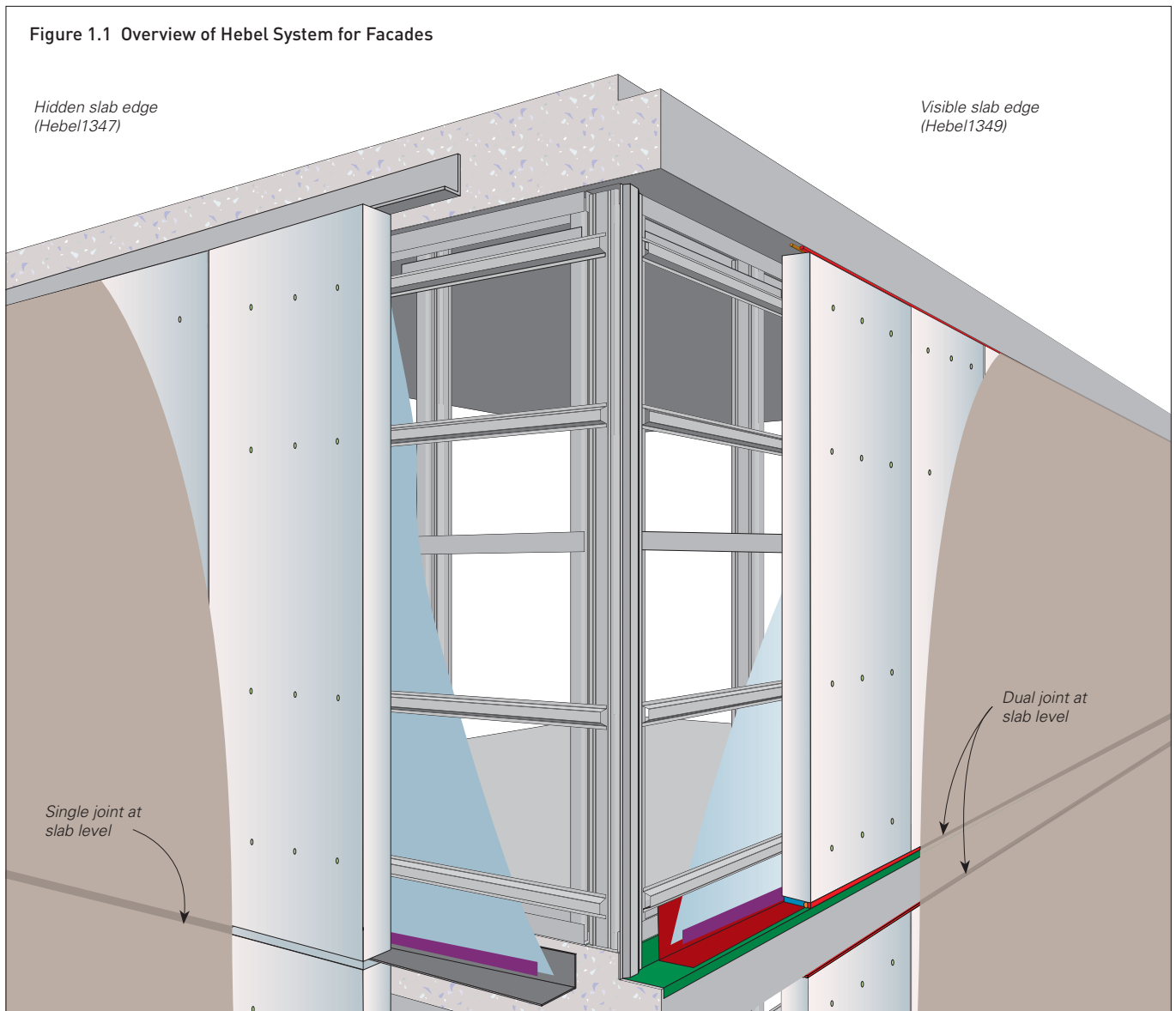

1.2 FACADE HIDDEN SLAB EDGE

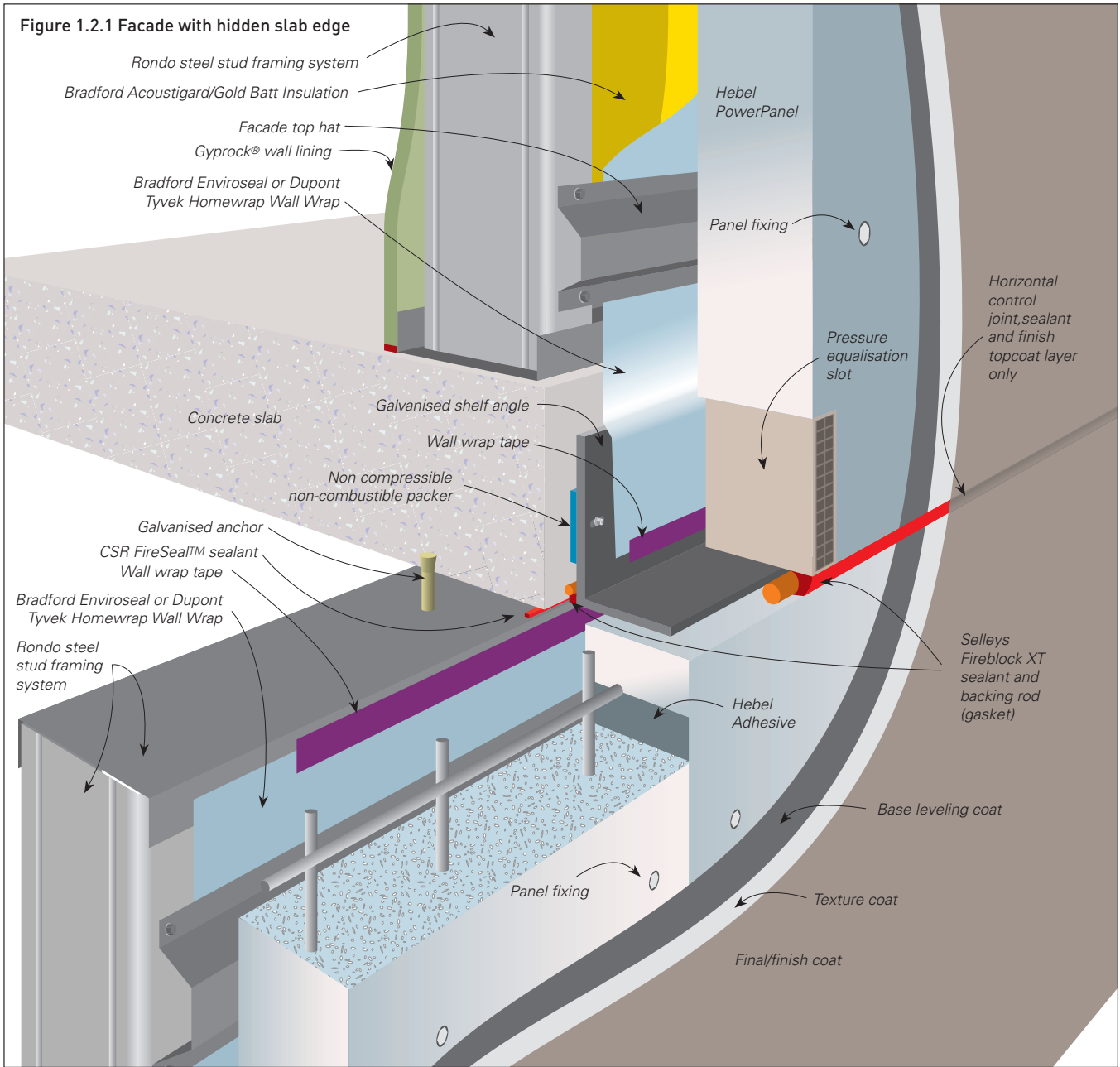

FACADE HIDDEN SLAB EDGE DETAIL

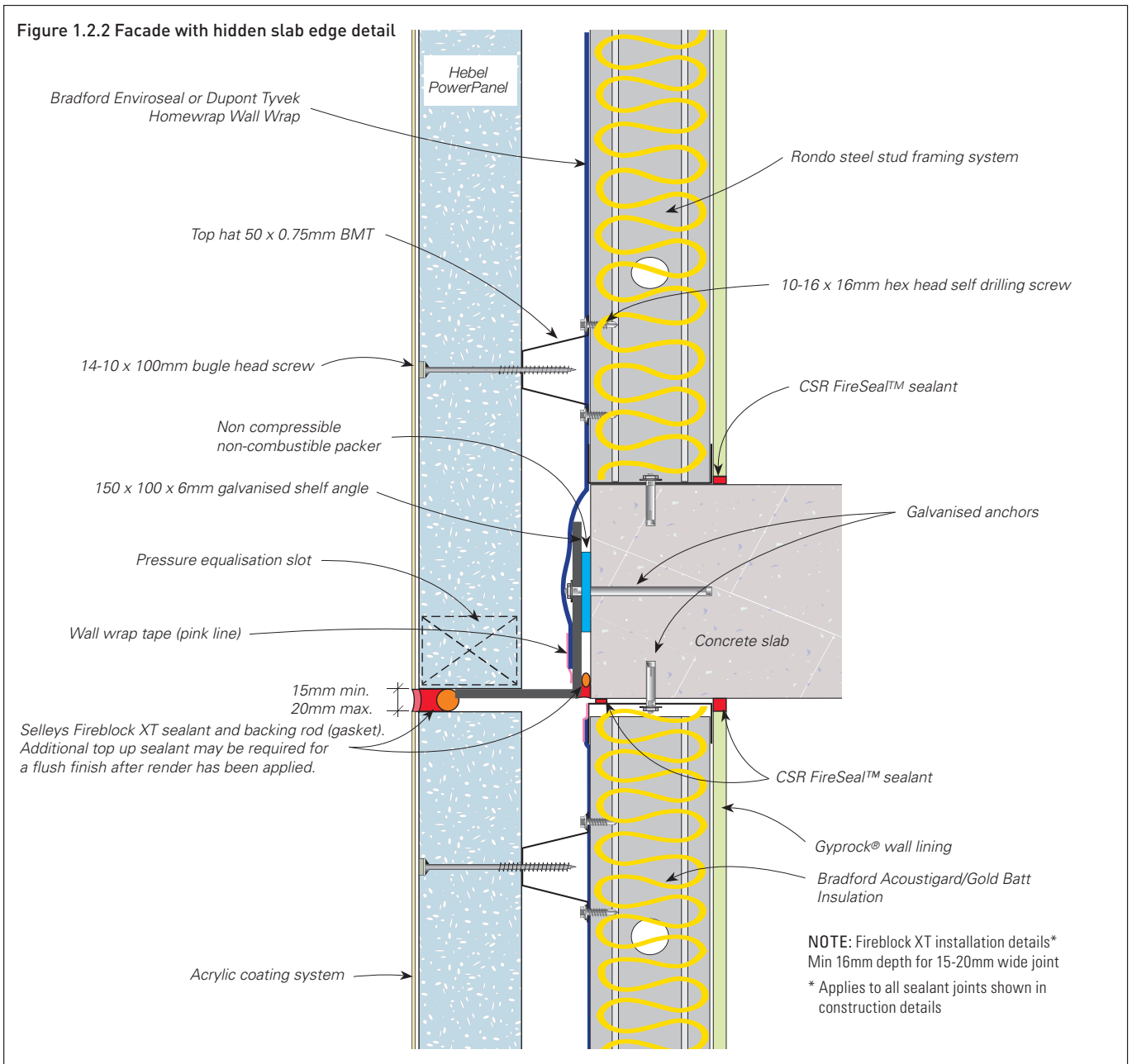

Alternatively the Selleys Fireblock XT sealant behind the steel shelf angle can be installed behind the top edge of the angle (above the packer) provided all bolt holes are also sealed with Selleys Fireblock XT

Table 1.2.1 Performance of facade hidden slab edge

System	Application	FRL	Wall lining	Insulation	Acoustic rating		Wall width (mm)	Thermal values	
					Rw	Rw+Ctr		Winter	Summer
Hebel1347	External to Internal	-/120/120 external fire source only	13mm Gyprock Standard Plasterboard*	90mm R2.2 Bradford Acoustigard 14 or 90mm R2.5 Bradford Gold Wall Batts	50	41	230 + coatings	3.08	2.93

*For wet areas use 13mm Gyprock Aquachek plasterboard or 9mm FC sheeting

1.3 FACADE VISIBLE SLAB EDGE

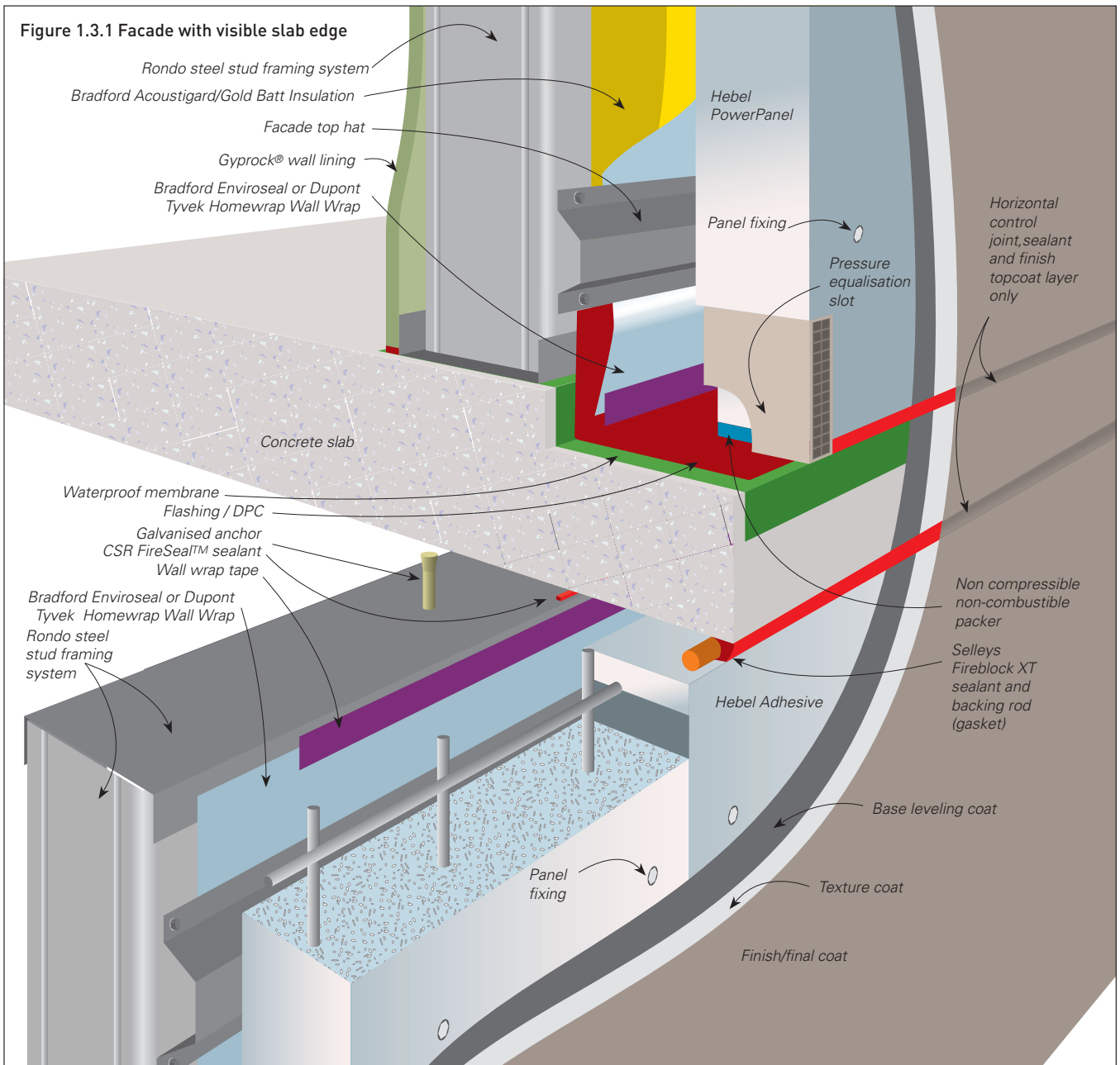

FACADE VISIBLE SLAB EDGE DETAIL

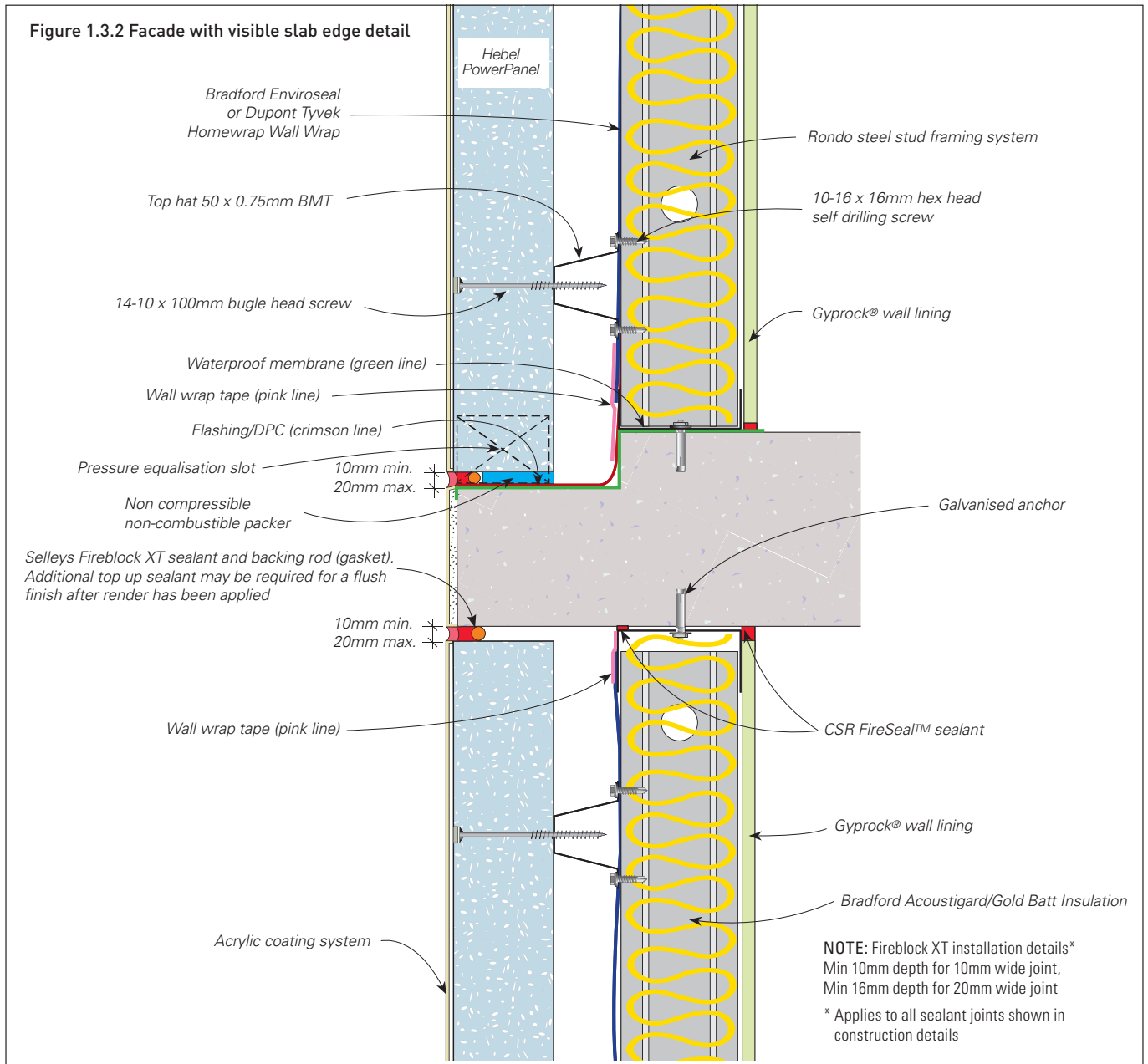

Table 1.3.1 Performance of facade visible slab edge detail

System	Application	FRL	Wall lining	Insulation	Acoustic rating		Wall width (mm)	Thermal values	
					Rw	Rw+Ctr		Winter	Summer
Hebel1349	External to Internal	-/180/180 external fire source only	13mm Gyprock Standard Plasterboard	90mm R2.2 Bradford Acoustigard 14 or 90mm R2.5 Bradford Gold Wall Batts	50	41	230 + coatings	3.08	2.93

*For wet areas use 13mm Gyprock Aquachek plasterboard or 9mm FC sheeting

1.4 BREEZEWAY

Figure 1.4.1 Breezeway wall detail

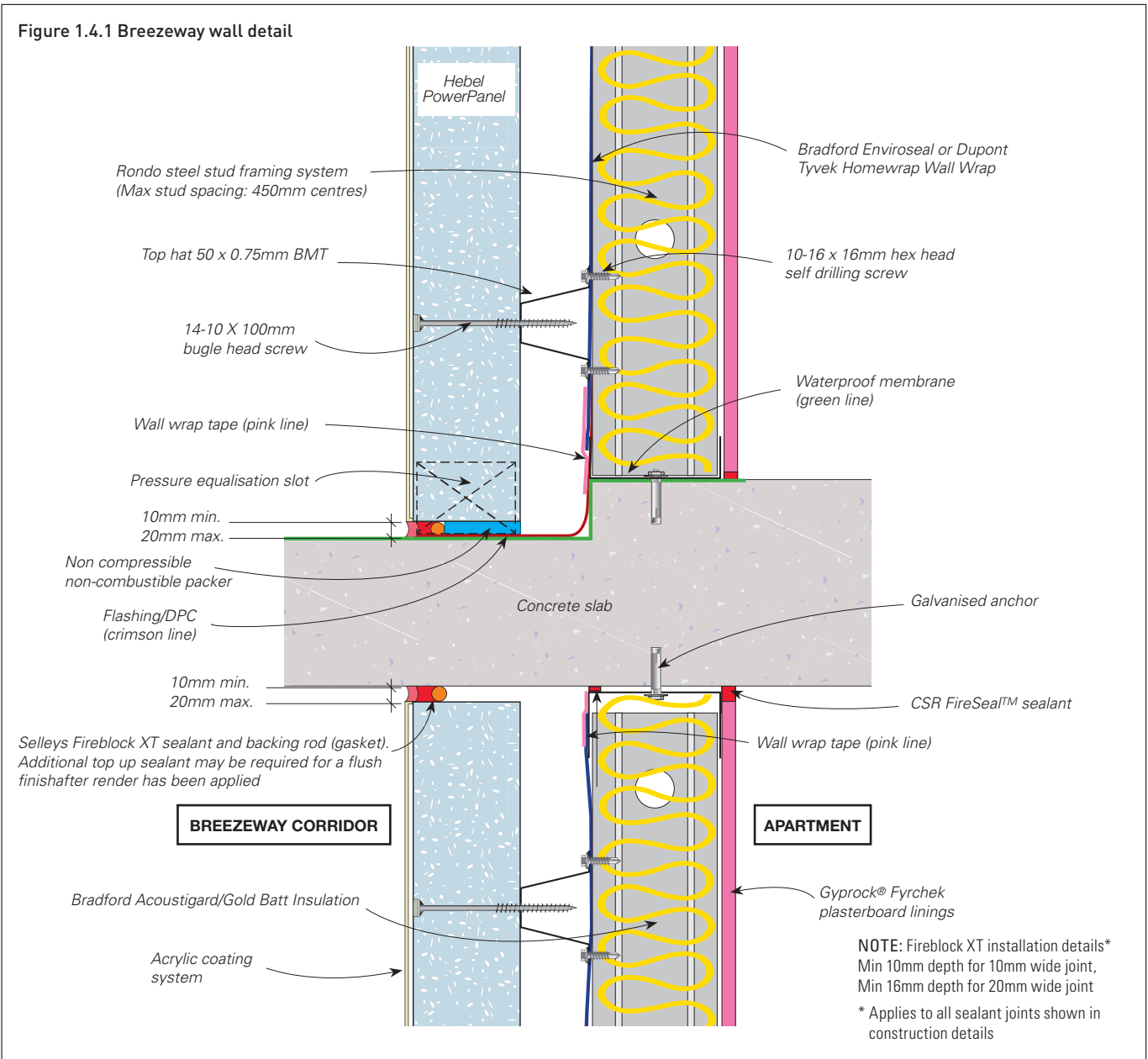

Maximum spacing of steel stud frame: 450mm centres.

Table 1.4.1 Performance of Breezeway wall

System	Application	FRL	Wall lining studs at max.450mm cts.	Insulation	Acoustic rating		Wall width (mm)	Thermal values	
					Rw	Rw+Ctr		Winter	Summer
Hebel1536	External to Internal	-/60/60 internal -/180/180 external	1 x 16mm Gyprock Fyrchek*	90mm R2.2 Bradford Acoustigard	50	42	233mm + coatings	2.97	2.83
Hebel1537	External to Internal	-/90/90 internal -/180/180 external	2 x 13mm Gyprock Fyrchek*	14 or 90mm R2.5 Bradford Gold Wall Batts	53	45	243mm + coatings	3.05	2.91
Hebel1538	External to Internal	-/120/120 internal -/180/180 external	2 x 16mm Gyprock Fyrchek*		54	47	249mm + coatings	3.10	2.96

*For wet areas use Gyprock Fyrchek MR plasterboard

1.5 BALCONY BLADE

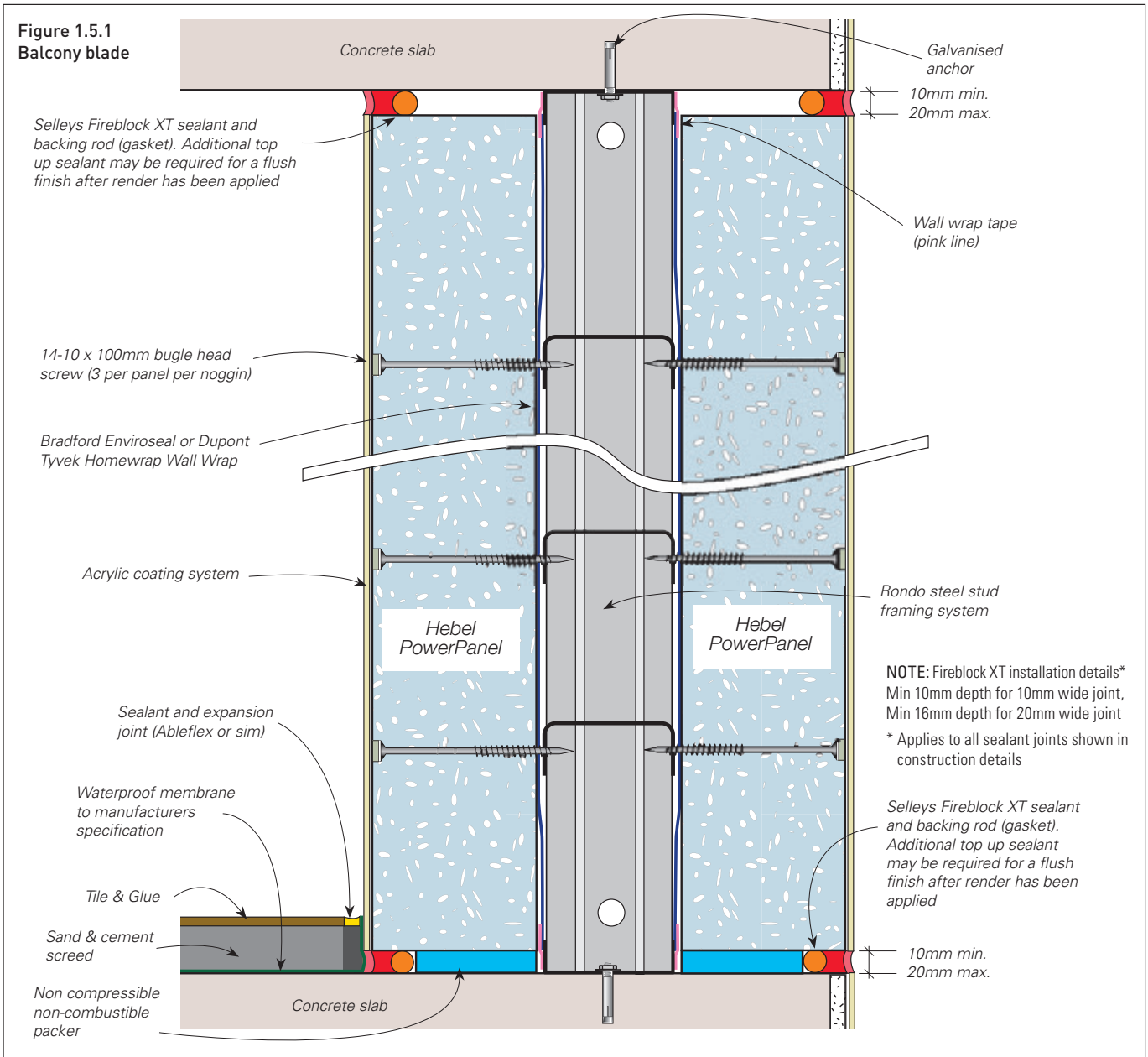

Table 1.5.1 Performance of balcony blade wall

System	FRL	Application	Steel stud framing system	Wall width (mm)
Hebel 1350	-/120/120	External to External	51mm @300cs	201mm + coatings

Fire Resistance Level (FRL) is based on fire assessment 34784200.6 by Exova Warringtonfire Aus Pty Ltd

Table 1.5.2 Wind pressure limits for balcony blade wall

Panel Height (m)	2.1	2.4	2.7	3	3.3	3.6	3.9	4.2	4.5
Ultimate Wind Pressure (kPa)	9.63	8.43	7.15	5.79	4.78	4.02	3.43	2.95	2.57
Serviceability Wind Pressure (kPa)	7.88	6.03	4.48	3.27	2.23	1.57	1.14	0.85	0.65

Notes

- Minimum steel grade has been assumed as 250MPa
- Minimum concrete grade has been assumed 25MPa
- Maximum masonry anchor spacing of 600mm.
- Installation of masonry anchors to be as per manufacturers recommendations.
- Assembly of and fixings of the steel frame to be in accordance with Rondos recommendations.
- Local pressure factors must be taken into consideration (in accordance with AS/NZS1170.2) in determining serviceability wind pressure applicable to the Hebel blade walls.
- Serviceability wind pressures are based on span/240 or max 12.5mm deflection.
- The Hebel Blade Wall system has not considered cyclonic wind loading.

1.6 SYSTEM DESIGN

HOW TO DESIGN A HEBEL FACADE WALL

STEP 1. Determine edge beam detail: visible edge beam (Hebel1349) or hidden edge beam (Hebel1347)

STEP 2. Determine the distance between supporting members (slab to soffit) to optimise the supporting structure (top hats and stud framing). Note that panels are one-way spanning vertically and supported by the horizontal top hats via screws.

STEP 3. Design Criteria. Identify the National Construction Code (NCC) Performance Requirements, and any additional project requirements:

- Purpose of structure (Class and importance)
- Imposed design actions (wind, local pressure regions)
- Damp and weathertightness
- Fire Resistance Level (FRL)
- Sound insulation performance (Rw, Ctr values)
- Energy efficiency (R-Value)
- Durability.

Earthquake loading has not been considered in this design and installation guide.

STEP 4. Select spacing for the top hats and studs (to be determined by stud frame manufacturer or project engineer) and construction tolerances. Refer to section 2.1.

STEP 5. Specify Bradford Enviroseal™ or DuPont™ Tyvek® HomeWrap® as the wall wrap for condensation control, weatherproofing and improving the thermal insulation performance.

STEP 6. Check adequacy of structural support framing, sound insulation, fire resistance level and construction tolerances.

STEP 7. Check the Performance Requirements of the Design Criteria (deflection criteria, damp and weathertightness, fire resistance level (FRL), sound insulation performance (Rw, Ctr values), energy efficiency (R-Value) and durability.

STEP 8. Complete detailed design and documentation.

IMPORTANT: A facade engineer must be involved in the selection, detailing and integration of a Hebel High Rise Facade System into all projects.

COMPLIANCE WITH NATIONAL CONSTRUCTION CODE OF AUSTRALIA (NCC)

All building solutions such as walls, floors, ceilings, etc. must comply with the regulations outlined in the NCC or other authority.

The NCC is a performance based document and is available in two volumes, which align with two groups of 'Class of Building':

- Volume 1 – Class 2 to Class 9 Buildings; and
- Volume 2 – Class 1 & Class 10 Buildings – Housing Provisions.

Each volume presents regulatory Performance Requirements for different Building Solutions for various classes of buildings and performance provisions.

These Performance Provisions include: Structure; Fire Resistance; Damp & Weathertightness; Sound Transmission & Insulation; Durability; and Energy Efficiency.

This design and installation guide presents information necessary to design a Hebel High Rise Facade System that complies with the Performance Requirements of the NCC. The designer must check the adequacy of the building solution for Performance Requirements outlined by the appropriate authority.

1.7 DESIGN AND DETAILING CONSIDERATIONS

BUILDING TOLERANCES

During the construction of a building, there are tolerances to control the accuracy of the building dimensions and locations to an acceptable standard.

Additionally, movement joints are required in the facade to accommodate the movement of the structure (see 'Movement Joints'). These tolerances are nominated in the appropriate specification for the project.

The Hebel High Rise Facade System is flexible and accommodating of the variations that occur during the construction of the support structure (building), such as variable slab to soffit heights and location of the slab edge.

The Hebel panels and lightweight structural steel framing can be fabricated to suit the onsite conditions.

The Hebel High Rise Facade System with hidden slab edge supports panels beyond the edge of the slab which accommodates the variability in slab position in the space behind the panel cladding. This system also eliminates the need for rendering a finished slab edge and the associated difficulties in coordinating labour and producing a quality finish to the slab edge.

The construction process of the Hebel High Rise Facade System provides a wall that can be accurately located. For concrete elements that are located beyond the finished surface plane, this will require rectification of the concrete.

CSR Hebel recommends that tolerances are specified in the project documents to ensure that in-situ concrete elements, such as columns and slab edges, are produced within the finished surface plane.

MOVEMENT JOINTS

During the life cycle of a building, the building and the materials that it is constructed from will move. These movements are due to many factors working together or individually, such as support structure movement (lateral sway or vertical deflection), thermal expansion and contraction and differential movements between materials. This movement, unless relieved or accommodated, will induce additional stress in different elements of the building, which may be relieved in the form of cracking. To accommodate these movements and relieve any induced stresses, which could potentially crack the wall, movement joints need to be installed. There are two categories of joints:

- Articulation joints (AJ) are provided to relieve induced stresses due to support structure movement. The joints make the walls more flexible by breaking the wall into a series of small panels. Differential movement between the facade and adjacent structural elements need to be accommodated with articulation joints.
- Control joints (CJ), (one type is an expansion joint), are provided to relieve the induced stresses resulting from thermal expansion or contraction of the AAC, or differential movement between the AAC and another material or structure, such as abutting walls, columns of concrete or brickwork. Control joints can also delineate coating shrinkage breaks. A joint may perform the function of either an articulation joint or control joint or both.

IMPORTANT: There are maximum length restrictions of Hebel facade between control joints. Control joints must be provided at:

- 6 metres maximum for continuous runs of walls at all external and re-entrant corners (unless otherwise approved by CSR Hebel)
- at control joints in the primary support structure
- for windows / door openings $\leq 2400\text{mm}$, a control joint is to be provided to one side of the window / door opening
- for windows / door openings $> 2400\text{mm}$, control joints are to be provided either side of the opening.

Vertical control joints should coincide with control joints in the supporting structure and anywhere that significant structural movement is expected where the wall abuts a vertical structure, such as a column, or adjacent to large openings, i.e. windows.

This design and installation guide proposes minimum widths for the movement joints.

The project engineer shall determine if the joints are sufficient to accommodate the movement of the specific project building. Typically, the vertical joint is a minimum 10mm wide and filled with an appropriate flexible sealant. A horizontal control joint is required beneath slabs or angles to accommodate any expected deflection. The magnitude of the deflection must be verified by the building designer. Typically, the horizontal joint is 15 - 20mm wide.

SEALANTS

All movement joints and gaps between the panels and infill framing or penetration framing must be filled with an appropriate flexible sealant. The sealant should be designed and installed in accordance with the sealant manufacturer's specifications. The specifications must provide information regarding priming the surface, geometry of sealant (width / depth ratio), sealant surface profile (concave), substrate preparation, etc. Where different types of sealants come in contact, the designer must ensure the sealants are compatible.

The external sealant in the control joints adjacent to windows should be extended to the inside face of the wall, beyond the sealant line of the windows. No gap should exist between both sealants. This sealant configuration is recommended at similar detailing issues.

Typically a backing rod (gasket) is used to control the depth of sealant and ensure the sealant is bonded on two sides only. The surface may require some preparation depending upon the type of sealant.

CONDENSATION

Condensation is a complex problem and can occur under a variety of conditions, not just cold conditions. Information on condensation is available from the Australian Building Codes Board in the ABCB Condensation in Buildings Handbook which should be referred to when building in areas where condensation is likely to occur.

In these cases, the appropriate use of a wall wrap as a vapour barrier or as thermal insulation, or both, can be effective in controlling condensation.

PANEL LAYOUT

Modular construction

The Hebel High Rise Facade System is essentially a flexible modular construction system. By adopting a few simple rules, significant savings can be gained in time and cost. This is achieved by the following:

- eliminating all onsite width cuts as this type of cutting will result in time loss, increased waste and requires treatment of cut reinforcement
- window and door penetrations: ensure 300mm multiples above and 600mm multiples wide for wall areas between windows and doors.
- planning the panel layout with special attention to the locations of openings and penetrations can significantly reduce the amount of onsite cutting
- at openings (windows and doors), it is recommended that a 600mm width panel be installed adjacent to the opening. For large openings, it may be necessary to provide additional structural steel to support the loads shed from the opening.

'Good Practice' and 'Poor Practice' layouts for vertically installed panels with various penetrations are illustrated in Figure 1.7.1 and Figure 1.7.2.

PENETRATIONS

Small service penetrations through the panel of the Hebel High Rise Facade System must allow for differential movement between the panel and the service. All penetrations are a potential source for water ingress and should be sealed with an appropriate flexible sealant.

IMPORTANT: The detailing of penetrations through any facade is critical. An incorrect sealant detail could have a detrimental effect on the system's performance characteristics. For example, a penetration through the drained cavity system with only the external surface being sealed would allow air to flow into the building, defeating the pressure equalisation behaviour.

WET AREA WALL CONSTRUCTION

All wet area walls shall be lined and waterproofed in accordance with Australian Standards and to NCC requirements. Gyprock Aquachek™ or Cemintel™ Wallboard are suitable lining materials for wet area applications.

CAVITY Baffles

Used vertically at the major corners of the building to limit the airflow within the cavity (typically 4 per level).

PRESSURE EQUALISATION (PE) SLOTS

PE Slots (Weepa) allow pressure equalisation to the wall cavity and permit drainage of any water or moisture from the cavity. Ideally located at control joints (CJ), 75mmx10mm pressure equalisation slots shall be installed at no greater than 3 metre spacings.

Figure 1.7.1 Good practice panel/penetration layout

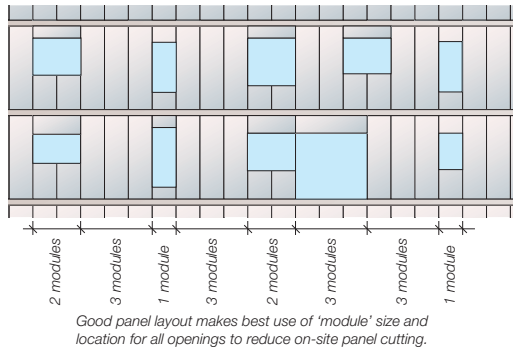

Figure 1.7.2 Poor practice panel/penetration layout

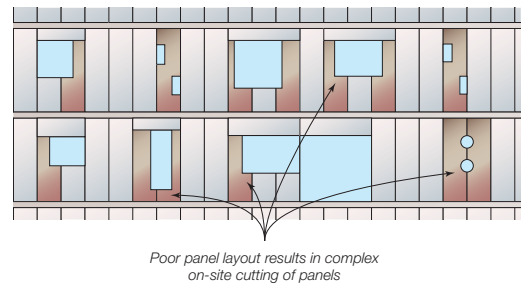

Figure 1.7.3 Typical multi-unit floor plan

The figure below is an example only and illustrates the typical placement of control joints, pressure equalisation slots and cavity baffles



- **Control Joint**
(no greater than 6m spacing)
- **Pressure Equalisation Slots**
(no greater than 3m spacing)
- **Cavity Baffle**

1.8 SYSTEM COMPONENTS

HEBEL POWERPANEL

The core component of High Rise Facade System is the 75mm thick, square edge PowerPanel, which is manufactured in a range of stock sizes as indicated in the following table:

Table 1.8.1 Hebel PowerPanel standard and made-to-length sizes

Panel Type	Profile	Reinforcement	Length (mm)	Width (mm)	Weight (kg/m ²)
Standard sizes (stock)	Square edge (nil profile)	Single mesh	1200	600	49
			2400	600	49
			2550	600	49
	Square edge (nil profile) AND Tongue & groove	Single mesh	2700	600	49
			2800	600	49
			2850	600	49
			3000	600	49
			3300	600	49
			3600	600	53
		Caged mesh	4200	600	53
Made-to-length sizes (5mm increments)	Square edge (nil profile) AND Tongue & groove	Single mesh	3300 max	600	49
		Caged mesh	Up to 4800	300-600	53

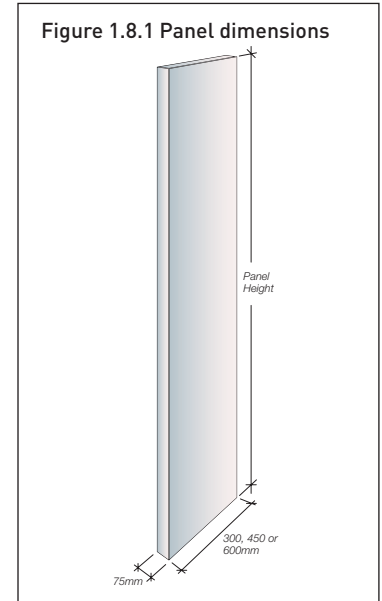

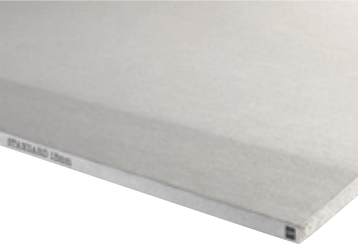



Table 1.8.2 Typical Hebel High Rise Facade System components

System Component	Hidden Slab Edge	Visible Slab Edge	Supplied by CSR Hebel
FRAMING SYSTEM			
Deflection head track: Rondo 92 x 50 x 1.15mm BMT (or approved equivalent)	✓	✓	
Base track: Rondo 92 x 32 x 1.15mm BMT (or approved equivalent)	✓	✓	
Lipped studs: Rondo 92 x 32 x 1.15mm BMT (or approved equivalent)	✓	✓	
Cleats: Rondo MAXIframe cleats 201, 201	✓	✓	
WALL SYSTEM			
Waterproof membrane		✓	
Wall wrap: Bradford Enviroseal™ or DuPont™ Tyvek® HomeWrap®	✓	✓	
Wall wrap tape	✓	✓	
Galvanised steel angle (corner support for wall wrap): 50 x 50 x 0.75mm	✓	✓	✓
Hebel High Rise Facade Top Hat 50mm x 4.8m x 0.75mm BMT (also used as a cavity baffle)	✓	✓	✓
Screw: 10-16 x 16mm hex head self drilling	✓	✓	✓
Shelf angle: 150mm x 100mm x 3m x 6mm	✓		✓
Galvanised anchor (to fix steel stud frame to concrete base and soffit)	✓	✓	
Galvanised chemical anchors at 900mm centres: M12 Hilti HVU (to fix shelf angle to slab edge)	✓		
Galvanised chemical anchors at 450mm centres: M10 Hilti HVU (to fix shelf angle to slab edge)	✓		
Galvanised mechanical anchors at 600mm centres: Hilti HSA-F M10 (to fix shelf angle to slab edge)	✓		
Non compressible non-combustible packers to suit	✓	✓	
Open cell backing rod (gasket)	✓	✓	
Selleys Fireblock XT	✓	✓	
CSR FireSeal™ sealant	✓	✓	✓
Hebel PowerPanel	✓	✓	✓
Hebel Anti-Corrosion Protection Paint	✓	✓	✓
Hebel Adhesive	✓	✓	✓
Hebel Patch	✓	✓	✓
Screw: 14-10 x 100 bugle head type 17 OR	✓	✓	✓
Screw: 14-10 x 90 hex head type 17	✓	✓	✓
Pressure equalisation slots	✓	✓	
Flashing / DPC	✓	✓	
Gyprock® plasterboard	✓	✓	
Bradford insulation	✓	✓	
COATING SYSTEM			
Dulux AcraTex AcraLite (lightweight repair & levelling compound)	✓	✓	
Dulux AcraTex AcraPatch High Build (base levelling and reinforcing layer)	✓	✓	
Dulux AcraTex Green Render Sealer (fast track primer)	✓	✓	
Dulux AcraTex AcraSkin (elastomeric texture and weatherproofing membrane)	✓	✓	

Table 1.8.3 Description of system components

Product	Description	
Hebel High Rise Facade Top Hat	Used to fix the Hebel PowerPanel to the structural support framing, the Hebel High Rise Facade Top Hat has been designed to improve building set out and ensure any water entering the cavity is directed to the back face of the panel.	
Hebel Shelf Angle	A shelf angle is used in the hidden slab edge system. It is the responsibility of the project engineer to confirm suitability of the angle, connection system and durability performance and additional protection requirements. <ul style="list-style-type: none"> • 150mm x 100mm x 3m x 6mm 	
Hebel Adhesive	Hebel Adhesive (supplied in 20kg bag) is used for gluing the panels together at vertical and horizontal joints.	
Hebel Patch	Minor chips or damage to panels are to be repaired using Hebel Patch (supplied in 10kg bag).	
Hebel Anti-Corrosion Protection Paint	Used to coat exposed reinforcement during cutting.	
Steel Stud Framework	Zinc coated steel studs, noggings and head and base tracks are used to create separated stud framework. The wall configurations outlined in this design and installation guide have been determined for cold-formed steel products manufactured by Rondo Building Services Pty Ltd. Additional information can be obtained from Rondo. For alternative stud types, the stud manufacturer or project engineer will be responsible for approving the substitute product as adequate for performance requirements and certification of such systems. All steel stud framework components are to be designed in accordance with framing manufacturer’s specifications, and AS / NZ S4600.	
Bradford Insulation	Manufactured in Australia, Bradford Glasswool batts provide excellent thermal resistance and acoustic performance properties. Bradford Glasswool products are manufactured by spinning molten glass, containing up to 65% recycled content, into fine wool like fibres. These are bonded together using a thermosetting resin and employ safe to handle FBS-1 biosoluble Glasswool formulation. Product meets AS / NZS4859 requirements to ensure performance over the life of the building.	

Product	Description	
<p>Wall Wrap (Refer to non-combustible construction on page 24)</p>	<p>The Hebel High Rise Facade System incorporates a vapour permeable wall wrap designed to control interstitial condensation, provide additional weatherproofing and improve thermal performance. The wall wrap is positioned between the top hats and steel stud support framing, and for optimum performance, joints and penetrations must be lapped and taped to manufacturer's specifications. Use 50 x 50 x 0.8mm Rondo galvanised steel angle on internal corners to prevent tearing.</p> <p>Hebel recommends:</p> <ul style="list-style-type: none"> • Bradford Enviroseal Residential Wall (RW) vapour permeable membrane with high water hold-out for Region A applications. • Bradford Enviroseal Commercial Wall (CW) vapour permeable membrane with high water hold-out Region B applications. <p>OR</p> <ul style="list-style-type: none"> • DuPont™ Tyvek® HomeWrap® 	
<p>Gyprock® Plasterboard</p>	<p>Hebel High Rise Facade System incorporates Gyprock plasterboard fixed to the steel stud on the internal side. The type, thickness and densities of plasterboard will be as per the specified facade requirements, which is typically 13mm Gyprock Standard Plasterboard. If internal fire rating is required, Gyprock Fyrchek linings are to be installed on the internal side. An internal FRL of up to 120minutes can be achieved using Gyprock Fyrchek linings.</p> <p>Additional information is available from CSR Gyprock.</p>	
<p>Fixings</p>	<ul style="list-style-type: none"> • PowerPanel to top hat 14-10 x 100mm bugle head type 17 screw or 14-10 x 90mm bugle head type 17 screw • Top hat to steel framing 10-16 x 16mm hex head self-drilling screw. 	
<p>DPC/Flashing</p>	<p>Plastic flashing minimum 100mm wide for wall junction and wider for base of facade wall when on exposed slab. Overlap details to manufacturer's specifications.</p>	

Product	Description	
Sealants	<p>Use Selleys Fireblock XT a high UV resistant, moisture curing sealant suitable for fire and acoustic rated construction.</p> <p>All gaps in internal and external junctions and movement joints must be caulked with appropriate flexible sealants. Sealants shall be installed in accordance with the sealant manufacturer's instructions.</p> <p>Sealants and primers (as required) must be compatible with the substrate material, such as flashings, Hebel PowerPanel, window frame material and coatings.</p> <p>Selleys Fireblock XT sealant installation: Min 10mm depth for 10mm wide joint, Min 16mm depth for 20mm wide joint.</p>	
Backing Rod (gasket)	<p>Backing rod (gasket) is used to enable correct filling of joints with sealant. Open cell type backing rod is recommended to enable sealant to cure from behind. The diameter of backing rod must be appropriate for the width of the gap being filled.</p>	
Waterproof Membrane	<p>Waterproof membranes must be applied in accordance with manufacturer's specifications and relevant codes - AS3740 and AS4654.</p>	
Cavity Baffles	<p>Used vertically at the major corners of the building to limit the airflow within the cavity (typically 4 per level). The Hebel Facade Top Hat can be used as the cavity baffle.</p>	
Pressure Equalisation Slots	<p>Proprietary slots such as Weepa should be installed in accordance with the manufacturer's instructions. Slots should be installed proud of the face of the PowerPanel to allow for thickness of render.</p>	
Packers	<p>Non compressible non-combustible PVC packers are used between the shelf angle and the PowerPanel below as a temporary packer to allow for gap above the panel below in the Hidden Slab Edge detail. These packers should be removed from this location before sealant is installed.</p> <p>When using the Visible Slab Edge detail, two 75 x 50mm packers should be used to support the PowerPanel on the slab edge.</p>	

2.1 STRUCTURAL PROVISIONS

OVERVIEW

The Hebel High Rise Facade System is a non-loadbearing facade which consists of vertical Hebel PowerPanel cladding and a support structure of lightweight structural (cold-formed) steel products (horizontal top hats and vertical studs). This section provides tables to assist the designer in the selection of stud and top hat spacings that ensure the panel remains fit for purpose under the imposed actions.

A description of the wall components is outlined in the System Components section.

The values in the design tables are determined based on the following assumptions:

- the panel is not cracked when subjected to ultimate wind pressures; and
- the bending stresses induced into the panel considered the effect of a deflecting support framing and wind pressure acting on the surface of the panel.

Guidance is given for the selection of stud and top hat products manufactured by Rondo Building Services Pty Ltd.

IMPORTANT: The design and approval of the lightweight structural (cold- formed) steel framing is to be provided by Rondo Building Services (or similar) and / or project engineer including certification of stud framing installation. The builder is to provide a letter of certification of stud installation following completion of stud framing.

IMPOSED DESIGN ACTIONS

The imposed design actions must be determined from AS/NZS1170 series of codes and are to be provided by the designer.

For the wind load, the value must be the maximum after all effects, such as internal, external, and local pressure factors, etc. have been applied where applicable. This value is required as an ultimate strength design value.

DEFLECTION GAPS

The width of deflection gaps at movement joints shall be nominated by the project engineer and sealant manufacturer, so that the sealant geometry can accommodate the magnitude of movement in the joint. A 15mm gap between the top of the panel and shelf angle / concrete soffit is typical for high rise multi-residential buildings.

AIR BARRIER SYSTEM

The facade designer must verify that the selected plasterboard and wall wrap has adequate capacity for the particular project.

STRUCTURAL DESIGN

Design Parameters

Rondo 92 x 1.15mm BMT lipped studs

Standard Rondo wall studs, wall tracks and deflection head tracks only

Deflection limit - SPAN / 360

Wind Loading Parameters

$VR = V1000 = 46\text{m/s}$

$C_{pe} = 0.8, -0.65$

$C_{pi} = -0.3, 0.2$

K_I in accordance with AS/NZS 1170.2:2002 M_z,cat assumed to vary with height

Notes:

1. Consult Rondo Building Services for applications outside these above situations.
2. Where the stud spacing is less than 300mm, using back to back studs at double spacing will require a custom deflection head track. Rondo should be consulted in this instance.

Table 2.1.1 Wall configuration and components

Wall Configuration	Description
Stud configuration	Rondo 92 x 32 x 1.15mm BMT lipped studs, 1 row of noggings mid wall height
Head track	Rondo 92 x 50 x 1.15mm BMT deflection head track , 1 row of noggings 100mm below head track
Base track	Rondo 92 x 32 x 1.15mm BMT track
Top hat	Hebel High Rise Facade Top Hat, 50mm x 0.75mm BMT
Wall linings	Hebel 75mm PowerPanel + coating system (external)
	1x 13mm Gyprock standard plasterboard (internal)
	Wall wrap (located between top hat members and steel studs)

Table 2.1.2 Hebel High Rise Facade System design - Region A

Region A		Stud Frame Height (metres)					
Wind Ult (kPa)	Wind Serv (kPa)	3.0	2.9	2.8	2.7	2.6	2.5
0.96	0.62	600	600	600	600	600	600
1.08	0.70	450	600	600	600	600	600
1.20	0.78	450	450	600	600	600	600
1.31	0.85	450	450	450	600	600	600
1.34	0.86	400	450	450	600	600	600
1.42	0.92	400	450	450	450	600	600
1.47	0.95	400	400	450	450	600	600
1.63	1.05	300	400	450	450	450	600
1.68	1.09	300	300	400	450	450	600
1.77	1.14	300	300	400	450	450	450
1.94	1.26	300	300	300	400	450	450
1.98	1.28	225	300	300	400	450	450
2.17	1.41	225	300	300	300	400	450
2.25	1.46	225	225	300	300	400	450

Notes:

1. Stud Spacing is in mm
2. All wall configurations in Table 2.2 require four (4) Hebel 50mm top hats (minimum)
3. Wind loads provided are upper limits
4. Table 2.2 has been prepared by Rondo Building Services for Rondo Steel Stud Frame.
- 5 (a) Rondo steel stud framing (or approved equivalent) must be specified in accordance with the project wind loads as determined by the project design engineer. A design certificate prepared by the stud frame manufacturer or project engineer should be provided to builder.
 (b) Steel stud framing must be installed in accordance with the manufacturer's or project engineer's specification.
 (c) The builder is to provide a letter of certification for stud installation following completion of stud framing.
 (d) CSR Hebel has engineered and tested the facade system to comply with the National Construction Code and relevant Australian Standards.

Table 2.1. 3 Hebel High Rise Facade System Design - Region B

Region B		Stud Frame Height (metres)					
Wind Ult (kPa)	Wind Serv (kPa)	3.0	2.9	2.8	2.7	2.6	2.5
1.64	0.66	450	450	600	600	600	600
1.83	0.73	450	450	450	600	600	600
1.92	0.77	400	450	450	450	600	600
2.04	0.82	400	400	450	450	450	600
2.23	0.90	300	400	450	450	450	450
2.27	0.91	300	400	400	450	450	450
2.47	0.99	300	300	400	450	450	450
2.50	1.00	300	300	400	400	450	450
2.62	1.05	300	300	300	400	450	450
2.74	1.10	300	300	300	400	400	450
2.78	1.11	225	300	300	400	400	400
2.96	1.15	225	300	300	300	400	400
3.01	1.21	225/5	300	300	300	300	400
3.10	1.24	225/5	225/5	300	300	300	300
3.31	1.33	225/5	225/5	300/5	300/5	300	300
3.37	1.35	225/5	225/5	225/5	300/5	300	300
3.50	1.41	100/5	225/5	225/5	300/5	300	300
3.61	1.45	100/5	100/5	225/5	300/5	300/5	300
3.70	1.48	100/5	100/5	100/5	300/5	300/5	300
3.78	1.52	100/5	100/5	100/5	225/5	300/5	300/5
3.84	1.54	100/5	100/5	100/5	100/5	300/5	300/5

Notes:

1. Stud Spacing is in mm.
2. Where /5 is shown adjacent to stud spacing in Table 2.3 five (5) Hebel 50mm top hats are required (minimum).
3. All other configurations require four (4) Hebel 50mm top hats (minimum).
4. Wind loads provided are the Upper Limits.
5. Table 2.3 has been prepared by Rondo Building Services for Rondo Steel Stud Frame.
6. a) Rondo steel stud framing (or approved equivalent) must be specified in accordance with the project wind loads as determined by the project design engineer. A design certificate prepared by the stud frame manufacturer or project engineer in regard to the stud framing specification should be provided to builder.
 (b) Steel stud framing must be installed in accordance with the manufacturer's or project engineer's specification.
 (c) The builder should provide a letter of certification for stud installation to builder following completion of stud framing.
 (d) CSR Hebel has engineered and tested the facade system to comply with the National Construction Code and relevant Australian Standards.

STEEL STUD FRAME

The steel stud frame shall be designed by Rondo or similar or appropriate project engineer.

Hebel PowerPanel is a reinforced autoclaved aerated concrete (AAC) product and the support structure should be designed to provide sufficient stiffness. The steel stud frame must be designed and constructed in accordance with AS3623 or AS/NZS4600 (NCC Performance Requirement) with following performance requirements for the studs:

Properties

- Cold-formed steel studs
- Minimum yield strength 275MPa (≥ 250 MPa Performance Requirement in the NCC).
- Minimum thickness 1.15mm BMT.
- Coating class Z275 (see Durability in System Performance section).

Lateral deflection limit

H/360 or 20mm maximum, under serviceability wind pressures in accordance with AS1170.2.

The deflection behaviour of the steel stud under the serviceability and ultimate strength loading conditions is assumed to be linear. The deflection limit at ultimate loading is taken as $H/170$ ($H/400 \times (V_s/V_u)^2$) for Regions A, B and C in AS/ NZS1170.2.

Vertical load

- Steel stud framing does not support the panel self-weight load except in the fire limit state for the hidden slab edge arrangement.

Connections

- Designer to specify fixings to accommodate vertical deflection and lateral sway of the supporting members (eg. slab).
- Provide fixings specification (mechanical fasteners – spacings and type).

Stud layout

- Additional steel studs and end connections around openings may be required to strengthen this area for loads transferred from the openings (window or door).
- It is the responsibility of the stud frame manufacturer or project engineer to specify the configuration of the support structure.
- The builder is to provide a drawing of the stud framing plan and details produced by the stud frame manufacturer (or project engineer) prior to commencement of facade installation.

Air barrier

A fully sealed air barrier is a compulsory requirement in the Hebel High Rise Facade System.

The internal plasterboard linings (fixed to the steel stud frame) are considered the primary air barrier in this facade system. The building wall wrap also functions as an air barrier under low external pressures.

As such, these internal linings and the building wall wrap need to be completely sealed to the main building structure (around the periphery and at penetrations through the linings) to ensure proper function of the pressure equalised system and avoid a pressure differential (between the facade cavity and the internal parts of the building) that could otherwise draw water into the internal habitable areas of the building.

STEEL TOP HAT

The Hebel High Rise Facade Top Hat has been designed in accordance with AS/NZS4600:

Properties

- Cold-formed steel top hats
- Top hat depth of 50mm
- Thickness 0.75mm BMT
- Minimum yield strength 275MPa (> 250 MPa Performance Requirement in the NCC).
- Coating class Z275 and Z450 coastal (see Durability in System Performance section)

Lateral deflection limit

- H/360 under serviceability wind pressures in accordance with AS1170.2.

Vertical load

- Top hats support no vertical load except in the fire limit state for the hidden slab edge arrangement.

Connections

- Minimum screw coating class in accordance with AS3566: Class 3 and Class 4.
- Screw capacities conforming to AS3566.

Top hat spacings

- Minimum number of top hats – 4.
- Top hats must be continuous over a minimum 2 spans, or for single spans, stud spacing must be less than two thirds of the nominated maximum stud spacing.
- The design tables nominate the number of top hats. The spacing of tophats is to be evenly distributed.
- Maximum top hat spacing of 900mm.

HEBEL POWERPANEL

The strength design of the Hebel PowerPanel has been carried out using AS5146 - Reinforced Autoclaved Aerated Concrete.

The load carrying capacity of the Hebel PowerPanel is influenced by several factors, such as:

- Imposed action (wind)
- Lateral stiffness of the supporting structure (lightweight structural (cold-formed) steel framing).
 - Stud size and spacings
 - Deflection limit
- Height of the wall
- Number and spacing of the top hats
- Number of screw fixings considered effective.

Hebel panels act as 'one-way' spanning structural members supported by the top hats. The specifications in Tables 2.2 and 2.3 are determined so that the Hebel panel is uncracked when subjected to ultimate wind pressures.

The steel top hat arrangement and stud spacing of the Hebel PowerPanel System for Facades can be determined from Tables 2.2 and 2.3.

The performance requirements of the Hebel PowerPanel are:

Cut panels

- All exposed reinforcement to be painted with a liberal coating of the anti-corrosion protection paint (Fentak).

Finishes

- Refer to Coatings in System Performance section.

Connections

- No. 14 -10 x 100mm bugle head type 17 screw or 14-10 x 90mm hex head type 17 screw
- Minimum screw coating class in accordance with AS3566: Class 3
- 3 screws per 600mm panel width for each top hat
- Minimum 2 screws per 400mm width (or less) for each top hat.

The design capacities of the Hebel PowerPanel cladding are in limit state format and intended for use with AS/NZS1170.2.

FIXINGS

Table 2.4 outlines the connection type and requirements for constructing Hebel High Rise Facade Systems detailed in this design and installation guide. The project engineer or framing manufacturer are responsible for specification of alternative details.

Shelf angle minimum anchor details

Options:

- M12 Hilti HVU galvanised chemical anchors are required at no more than 900mm centres (for embedment depth of 110mm).
- M10 Hilti HVU galvanised chemical anchors are required at no more than 450mm centres (for embedment depth of 90mm).
- Hilti HSA-F M10 galvanised mechanical anchors are required at no more than 600mm centres (for embedment depth of 50mm into uncracked 150mm min. concrete slab).

Note: Minimum edge distance 70mm to underside of slab.

Table 2.1.4 - Fixing details

Fixings For	Fixing Type	Number of Fixings and Spacing
Top/bottom Track to Structure	M8 Dynabolt + 25 x 3mm load sharing washer	600mm max. spacings. Project engineer or framing manufacturer to specify layout
Top Hat to Stud	#10 metal tek screws	2 fixings at each stud (one fastened through each Top Hat leg)
Panel to Top Hat	14 - 10 x 100mm bugle head type 17 screw or 14-10 x 90mm hex head type 17 screw	3 per 600mm width panel at each top hat

* Capacity calculated in accordance with AS4600

2.2 FIRE RESISTANCE PERFORMANCE

The Hebel High Rise Facade System can be subjected to a fire loading as the result of either an external fire source, or an internal fire source. When the wall requires a fire resistance level (FRL) rating, Hebel provides the following guidance.

Where necessary, the designer must ensure the structural support framing and its connections are adequate when subjected to fire conditions.

EXTERNAL FIRE SOURCE

For an external fire source, the excellent fire resistance qualities of the Hebel PowerPanel cladding protect the structural support framing, and provide a high fire resistance level for the facade system.

The Hebel High Rise Facade System has an FRL of -/120/120 on the Hidden Slab Edge detail and -/180/180 on the Visible Slab Edge detail, when exposed to an external fire source.

NOTE: The FRL rating of the wall can be affected by the penetrations and the method adopted to protect these penetrations. A fire collar with a -/120/120 FRL rating will govern the FRL of the wall, even if the wall configuration has a FRL rating of -/180/180.

INTERNAL FIRE SOURCE

If the Hebel High Rise Facade System requires protection from an internal fire source, for example buildings of two storeys or less as described below, an internal lining system to protect the structural support framing, or an alternative fire protection system such as automatic external wall-wetting (sprinklers) is necessary.

The protective lining system can consist of CSR Gyprock Fyrchek™ plasterboard fixed to the support framing. Refer to Hebel Breezeway wall systems: Hebel1536, Hebel1537 and Hebel1538. The Hebel Breezeway walls can achieve an FRL up to -/120/120 when exposed to an internal fire source.

The steel frame manufacturer or project engineer must approve the connection arrangements for any fire rated lightweight steel support framing.

Fire certificates and reports

Copies of the test reports and/or opinions can be obtained by contacting CSR Hebel.

DESIGN CONSIDERATIONS

Pressure equalisation slots

Vents and pressure equalisation slots are to be protected by spark guards made from corrosion resistant steel, bronze or aluminium mesh with a max-aperture size of 1.8mm.

Fire stop penetrations

Penetrations through a Hebel High Rise Facade System to accommodate pipework, electrical cabling or ductwork must be protected (fire stopped), to prevent the spread of fire through the penetration. The penetration can be protected with proprietary products, such as:

- fire rated sealants
- fire collars and intumescent wraps
- fire rated mortars
- fire rated pillows
- fire rated switch boxes.

Contact the manufacturer to obtain the appropriate product / solution and installation method for the application and wall configuration.

SHELF ANGLE

The shelf angle is required in situations where the Hebel PowerPanel is located in front of the slab (Hebel1347). The base angle acts as a partial support and as a shelf to rest the panel on during the installation of the panel.

Shelf angle butt joints must be fully sealed with a suitable fire rated sealant in order to seal cavity vertically between apartments (SOUs) on different floors.

NOTE: Stepped slab construction: where the floor slab may change in level, the shelf angle must remain continuous around the building. This may require vertical sections of shelf angle to be installed to connect discontinuous sections of shelf angle (Hidden Slab Edge detail only).

NON-COMBUSTIBLE CONSTRUCTION

All elements of the Hebel high rise façade wall system used either in the Façade Hidden Slab Edge system or the Façade Visible Slab Edge system either are or have been deemed non-combustible as outlined in the following:

NCC 2019 Volume One clause C1.9 – Non-combustible building elements

- Open cell backing rod (gasket): The requirements of C1.9(a)(b) of NCC 2019 Volume One do not apply to Gaskets as included in Clause C1.9(d)(i).
- Sealants & Caulking: The requirements of C1.9(a)(b) of NCC 2019 Volume One do not apply to Sealants or Caulking as included in Clause C1.9(d)(ii) & (iii) respectively.
- Steel stud frame and Hebel Facade Top Hat made of galvanized steel are non-combustible materials.
- Shelf Angle (Façade Hidden Slab Edge system) made of galvanized steel is a non-combustible material.

- Bradford Enviroseal™ or DuPont™ Tyvek® Homewrap®: Clause C1.9(e)(vi) in NCC 2019 Volume One states that sarking-type materials that do not exceed 1mm in thickness and have a Flammability Index of not greater than 5 may be used wherever non-combustible material is required. The characteristics and properties of both Bradford Enviroseal™ and DuPont™ Tyvek® Homewrap® satisfy the requirements of Clause C1.9(e)(vi). The tape(s) used to affix wall wraps to the steel stud frame are to be compatible with the wall wrap type and as recommended by the wall wrap manufacturer and are to satisfy the same properties as outlined for the wall wrap characteristics above.
- Bradford Acoustigard and Gold Wall batts: Tested to AS1530.1 and are non-combustible.
- Gyprock Plasterboard: Clause C1.9(e)(i) in NCC 2019 Volume One states plasterboard may be used wherever non-combustible material is required. Gyprock plasterboard satisfy the requirements of Clause C1.9(e)(i).
- DPC Flashing and slab waterproof membranes: Clause C1.9(d)(vii) in NCC 2019 Volume One states that damp-proof courses may be used wherever non-combustible material is required. The base DPC flashing (used in the Façade Visible Slab Edge system) and waterproof membranes (used Façade Hidden Slab Edge system) satisfy the requirements of Clause C1.9(d)(vii).
- Non-compressible packers, non-combustible packers i.e compressed fibre cement, or similar

NCC 2019 Volume One clause C1.14 – Ancillary Elements

- Acrylic coating system: Clause C1.14(l) in NCC 2019 Volume One – with regard to those applied to an external façade wall - states that an ancillary element must not be fixed, installed or attached to the external face of an external wall that is required to be non-combustible unless it is a paint, lacquer or similar finish. Expert opinion provided by The Coatings Consultancy (TCC18056-20200227) concludes that the following coating types are classified as paints and therefore fall under the exemption in NCC 2019 Vol 1 Clause C1.14 (l)
 - AS/NZS 4548 Part 1: Wall coatings—Latex extensible
 - AS/NZS 4548 Part 2: Latex finish coatings—High-build, low profile
 - AS/NZS 4548 Part 3: Latex—Textured coatings—Non-aggregate
 - AS/NZS 4548 Part 4: Latex—Textured coatings—Aggregate filled

SPANDREL WALLS

Vertical fire separation of openings is required in external walls where the vertical projection falls no further than 450mm outside the lower opening (measured horizontally). The external wall must therefore be able to perform as a spandrel wall between the openings, with a minimum FRL of 60/60/60.

A spandrel wall shall contain a minimum total height of 900mm and extend at least 600mm above the surface of the intervening floor between the openings.

The Hebel facade walls contains an FRL of 60/60/60 when acting as a spandrel wall between openings and hence the Hebel facade is a suitable spandrel system for Class 2 to 9 buildings.

CSIRO fire assessment report FCO-3039 provides the fire compliance for the Hebel facade system acting as a spandrel wall.

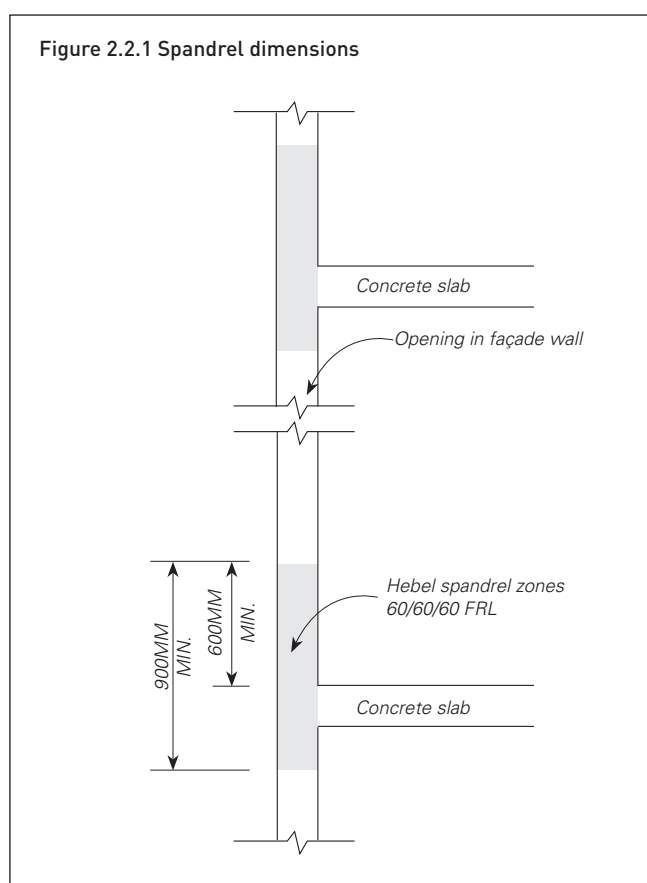

2.3 WEATHERTIGHTNESS

The primary goal in facade design is the provision of a building solution that manages the environmental conditions that the facade is subjected to during its design life. Of the various conditions, the prevention of water ingress is critical.

The Hebel High Rise Facade System is a high quality rain screen which uses pressure equalisation to provide an external wall system that eliminates water being drawn through the rain screen due to a pressure differential.

The principal of pressure equalisation is, where wind acting on the external surface of the facade can gain access to the cavity through pressure equalisation slots, the pressure on both sides of the cladding become similar and therefore removes any suction pressures from the cavity side. The elimination of a pressure differential significantly reduces the process of water being drawn through a penetration in the external coating / sealing system and the cladding.

The pressure equalisation slots are located at the base of the wall, and therefore no water ingress will occur over the height of the wall. This system ensures a dry cavity and utilises the slots provided for pressure equalisation to drain any water that seeps through the slots due to rain driven in by high winds. The cavity should not be used as a means of draining other building elements such as openings and penetrations.

A mandatory part of the Hebel High Rise Facade System is the wall wrap, which is installed on the external side of the stud frame to seal the cavity space.

The wall wraps specified for the Hebel High Rise Facade System (Bradford Enviroseal™ RW, Bradford Enviroseal™ CW and DuPont Tyvek Home Wrap) are vapour permeable building wraps. These wall wraps must be designed and installed in accordance with AS/NZS 4200 Part 1 - materials and Part 2 - installation.

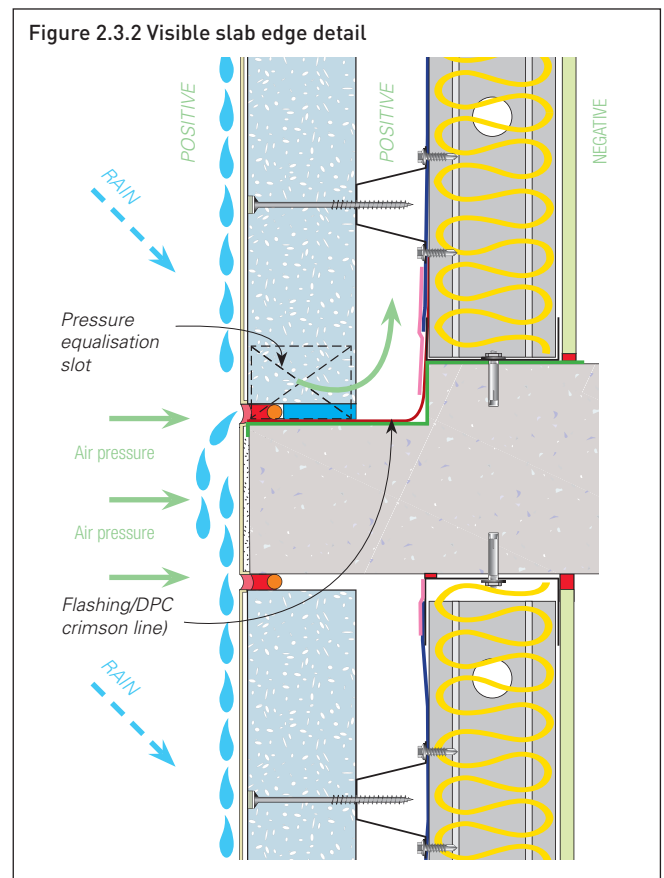
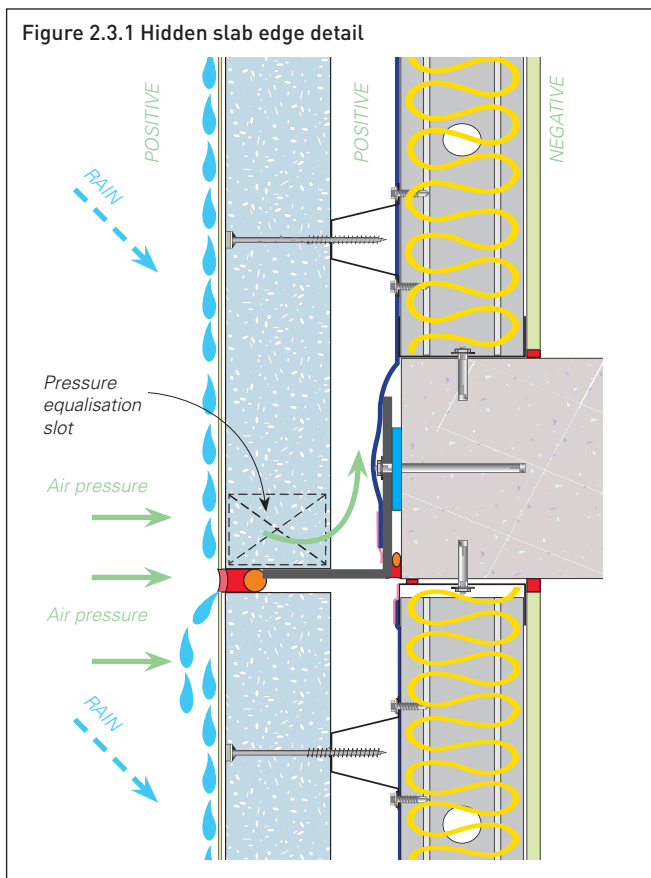

2.4 FINISHES

2.4.1 COATINGS

CSR Hebel has worked with Dulux® AcraTex® in development of coating systems to meet the specific requirements of the Hebel panel substrate.

Table 2.4.1.1

Dulux Acratex Coatings Systems Guide For Hebel High Rise Facade System *	Dulux Product Code	Duspec Data Sheet	Usage
SLAB EDGE REPAIR AND LEVELLING – Hebel Visible Slab Edge Design Dulux AcraTex AcraLite	19385979-12L	AUDA 1614	
AcraLite is a preblended lightweight polymer & fibre reinforced levelling compound supplied in a dry powder form. <ul style="list-style-type: none"> Apply in layers of 4-12mm up to 25mm. Apply a slurry key coat (“dash coat”) followed by multiple filling layers as required. Key coat mix ratio: <ul style="list-style-type: none"> Mix 5 parts Water to 1 part AcraBond and use as gauging liquid. Mix gauging liquid with AcraLite powder to make a slurry and apply a 70% “dash coat” Allow to firm before applying subsequent filling layers Filling layers: <ul style="list-style-type: none"> Mix 1 bag (10kg) AcraLite to 6.5L clean potable water. Allow to activate for 5 minutes. Adjust consistency with up to 0.5L water (once only) and apply up to 12mm thick layers. Allow to firm on the wall and screed level. 			Approx. 0.7 kg / sq m per mm filling depth
SKIMCOAT LEVELLING LAYER Dulux AcraTex AcraPatch High Build mixed with RenderWall	194 85841-15L	AUDA0440	
AcraPatch High Build is a flexible acrylic levelling compound supplied in wet form to which RenderWall is added onsite. <ul style="list-style-type: none"> Mix with RenderWall and apply in 3-5mm layers and float finish to a sand finish profile. AcraPatch HB / RenderWall mix ratio: <ul style="list-style-type: none"> Pre-mix 20 kg (1 bag) RenderWall with 4L clean potable water to form a stiff RenderWall mix Mix and divide equally a 15L pail of AcraPatch High Build into 2 pails (ie 7.5L in each) Add half of the RenderWall wet mix to each 7.5L of AcraPatch High Build and mix. 			AcraPatch HB RenderWall mix 1L / sq m per mm cover
COATING SYSTEM Dulux AcraTex AcraSkin Low Profile Texture			sq m per lt
PRIMER: Dulux AcraTex Green Render Sealer Apply by conventional nap roller to avoid efflorescence	19420802-15L	AUDA 1582	10
TEXTURE LAYER: Dulux AcraTex AcraSkin Apply by medium cell texture roller	19485675-15L	AUDA 1392	3
TOPCOAT : Dulux AcraTex AcraSkin Apply by conventional med-long nap roller	19485675-15L	AUDA 1392	4
MOVEMENT JOINT TREATMENT			
Expansion joints must be in accordance with Hebel High Rise Facade Design and Installation Guide including the use of backing rod (gasket) as specified. Dulux recommends filling of movement joints AFTER installation of the coating system levelling layer. <ul style="list-style-type: none"> Mastic filled joints should then be masked with 6mm tape prior to application of the texture layer – remove tape before texture dries. Application of the system topcoat should be continuous over the entire area including mastic filled joint providing final colour uniformity. Minor cracking of the topcoat over joint mastic may occur due to movement and is not considered a coatings defect. 			

*The Hebel High Rise Facade System and Dulux AcraTex Coating Systems must be installed in full accordance with this design and installation guide and relevant Product Data Sheets & Specifications.

Typical process: horizontal control joint (CJ) for visible slab edge detail	
Design	specified where Hebel panel installation exposes the concrete slab edge which is typically recessed and not aligned to the Hebel PowerPanel face.
Prep A	pre-fill horizontal control joints to level the slab edge flush with the Hebel PowerPanel surface with AcraLite - as per Slab Edge Repair and Levelling detail.

Typical process: vertical control joint (CJ)	
1	Skimcoat Levelling Layer System installation - as per Coatings System detail. Care must be taken to ensure movement joints remain free of levelling compound or mark accurately in planning to recut joints.
2	accurately mark and recut movement joints and clean out in preparation for sealant installation. Where fireproof mastic is installed, recut joint only to the depth of the installed mastic.
3	install backing rod (gasket) as per Hebel specification and joint mastic manufacturer’s recommendations.
4	install approved sealant (fire rated as required) as per manufacturer’s recommendations. Sealant must be compatible with external coating system. Care must be taken to ensure mastic is not spread on panel face.- Best practice is masking of either side of joint prior to mastic install.
5	mask cured mastic with 6mm tape prior to installation of texture layer. Install texture layer as per Coating System detail.
6	install the final weatherproofing topcoat layer over the entire area including the mastic joint providing colour uniformity across the joint.

SLAB EDGE ALIGNMENT

Pre-filling will be required where there is misalignment between in-situ concrete elements, such as slab edges and columns, and the finished wall plane. CSR Hebel recommends establishing concrete tolerances that result in the unrendered concrete surfaces being located behind the finished wall plane. This will eliminate the need for scabbling of the concrete and / or building out the wall surface. (Refer to Coatings section for pre-filling and coating detail of visible slab edge).

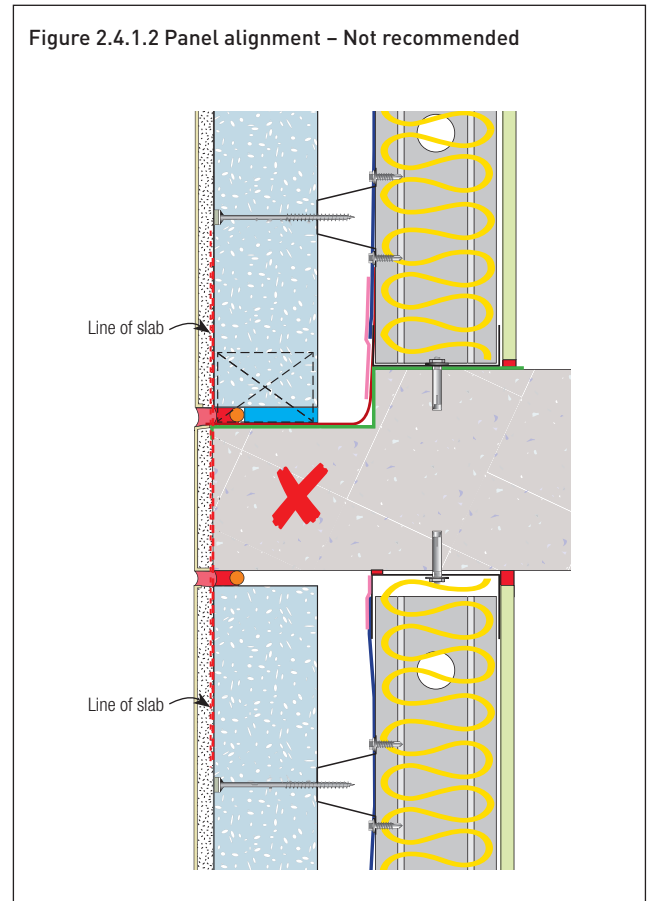
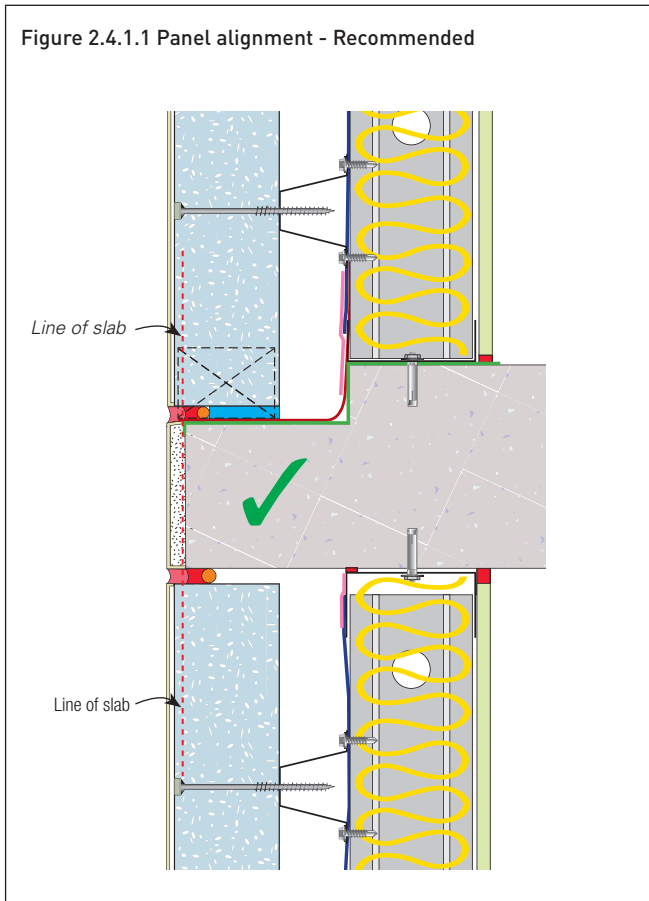

2.4.2 SUPPLEMENTARY CLADDING OVER HEBEL FACADE

Supplementary cladding can be fixed to the Hebel facade system. The Hebel High Rise Facade acts as the structural backing for the supplementary cladding.

It is the responsibility of the project certifier to approve and sign off the compliance of the Hebel facade system when supplementary cladding is fixed to the system. Contact CSR Hebel for more information.

2.4.3 POWERPATTERN™ PANELS

Hebel PowerPattern™ range introduces a collection of patterns pre-routed onto the Hebel panels offering unparalleled design flexibility. The range comprises of 4 design collections. Modular in design and intended to work with the other panels in the collection.

The Hebel PowerPattern™ system uses the same system components as the Hebel facade system and can be installed either with an exposed or hidden slab edge.

The Hebel PowerPattern™ Collections are designed to be paired with a range of compatible coating systems that can be painted, sprayed-on, rolled on or applied using render to achieve a range of different colours, textures and finishes. For more information on Hebel's recommended coating systems, please visit our website.

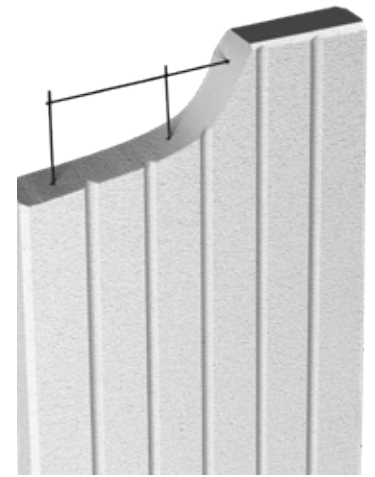

PowerPattern Lineal

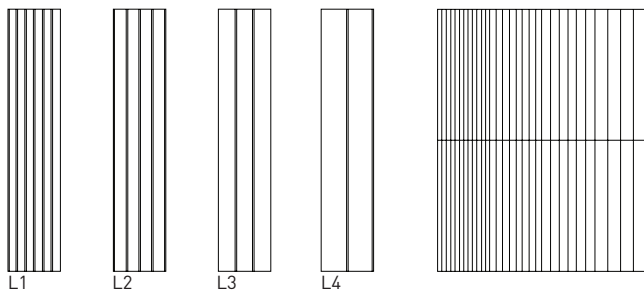

PowerPattern Prism

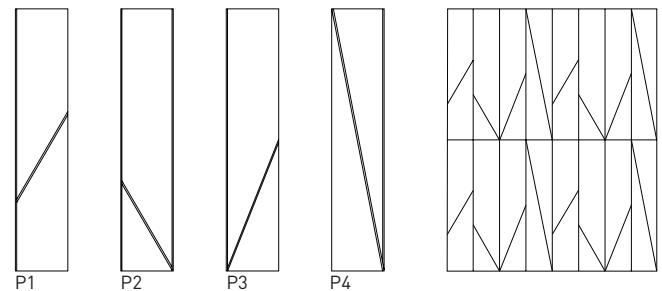

PowerPattern Geometric

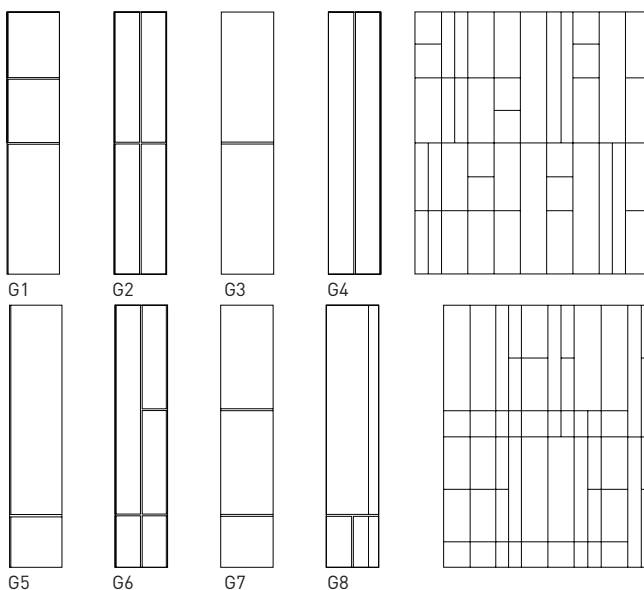

PowerPattern Organic

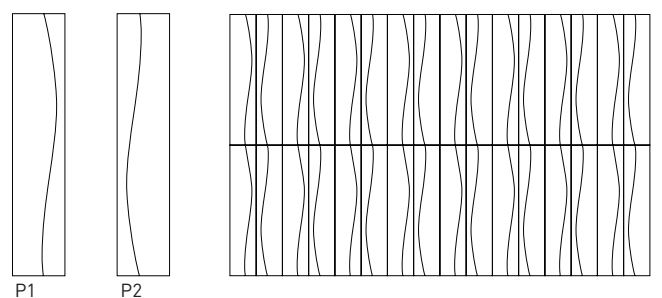

Standard Panel Size
 3000m x 600mm x 75mm
 3050m x 600mm x 75mm
 3100m x 600mm x 75mm
 3300m x 600mm x 75mm
 Also available in custom lengths.

Table 2.4.3.1 Performance of PowerPattern System

System	Application	Slab Edge Detail	FRL	Wall Lining	Insulation	Wall Width (mm)	Thermal Values	
							Winter	Summer
Hebel2002	External to Internal	Hidden Slab Edge	-/120/120 (from outside only)	13mm Gyprock Standard Plasterboard	90mm R2.2 Bradford Acoustigard 14 or 90mm R2.5 Bradford Gold Wall Batts	230+coatings	3.47	3.27
Hebel2003		Visible Slab Edge	-/120/120 (from outside only)	13mm Gyprock Standard Plasterboard		230+coatings	3.47	3.27
Hebel2004		Hidden and Visible Slab Edge	-/120/120 from outside, -/60/60 from inside*	16mm Gyprock Fyrchek	90mm R2.2 Bradford Acoustigard 14 or 90mm R2.5 Bradford Gold Wall Batts	233+coatings	3.02	2.82
Hebel2005		Hidden and Visible Slab Edge	-/120/120 from outside, -/90/90 from inside*	2x13mm Gyprock Fyrchek		243+coatings	3.08	2.88
Hebel2006		Hidden and Visible Slab Edge	-/120/120 both ways*	2x16mm Gyprock Fyrchek		249+coatings	3.12	2.91

* 450mm max stud spacing where FRL is required from the inside

2.5 ACOUSTIC PERFORMANCE

OVERVIEW

The NCC presents the Performance Requirements for sound insulation ratings. The sound insulation ratings set minimum values to consider two types of sound: airborne sound and impact generated sound.

The Performance Requirements for airborne sound insulation and impact sound insulation ratings are dependent upon the form of construction (ie. walls or floors), Class of Building, and the type of areas being separated. The airborne sound performance requirement is a value that could be the weighted sound reduction index (Rw) or weighted reduction index with spectrum adaptation term (Rw + Ctr). The impact sound performance requirement is a value called the weighted normalised impact sound pressure level with spectrum adaptation term (Ln,w + CI).

The NCC does not provide Performance Requirements for the airborne sound and impact generated sound insulation ratings for a building envelope. These requirements are set by the relevant local authority.

DESIGN RECOMMENDATIONS

1. CSR Hebel recommends engaging a reputable acoustic consultant on a project-by-project basis to provide design advice and installation inspections.
2. When specifying the appropriate Hebel High Rise Facade System, the designer or specifier must be aware that the laboratory Rw values are almost always higher than the field measured values. Therefore, allowances should be made for the lower expected field values during the selection of the system.
3. Separate advice from a specialist acoustic consultant should be sought to determine the effect on acoustic performance due to any changes to the Hebel High Rise Facade System, and any required modification of the installation details pertaining to the systems.
4. Using higher density or thicker insulation or plasterboard, will generally maintain or increase the acoustic performance of the Hebel High Rise Facade System.
5. The acoustic performance values of the Hebel High Rise Facade System is the expert opinion of Acoustic Logic. They do not constitute a field performance guarantee as factors such as the presence of flanking paths, quality of installation, onsite detailing of wall junctions, room shapes and sizes, etc. can significantly affect field performance.

Maximising the field performance depends on the following factors:

- The systems are installed in accordance with the manufacturer’s standard installation details
- Good quality installation practices including the sealing of all junctions and joints and maintaining specified clearances
- The systems are installed with all junctions acoustically sealed so that negligible sound transmission occurs at these points
- All services penetrations etc. are acoustically sealed and treated so that negligible sound transmission occurs through these points
- Flanking paths are eliminated and the structures into which the systems are installed are capable of allowing the nominated rating to be achieved. To minimise the transfer of sound through the Hebel High Rise Facade System into the adjacent unit, it is suggested that a control joint be provided to break the mechanical path for the transmission of impact sound and other vibration
- Site testing conditions.

2.6 ENERGY EFFICIENCY

NATIONAL CONSTRUCTION CODE (NCC)

The NCC is available in two volumes: Volume 1 – Class 2 to Class 9 Buildings; and Volume 2 – Class 1 & Class 10 Buildings – Housing Provisions. Each volume presents the Performance Requirements for the efficient use of energy for internal heating and cooling in buildings. Volume 1, Section J is the relevant section for the Hebel High Rise Facade System.

The Performance Requirements for energy efficiency ratings are dependent upon the form of construction (ie. walls or floors), Class of Building, and the type of areas being separated. The performance requirement is a value that is the Total R-Value, which is the cumulative total of the individual R-Values of the building system components.

THERMAL INSULATION

It is recommended that insulation materials be installed to enhance thermal insulation properties and occupant comfort. Insulation also improves the acoustic performance of the wall against outside noise.

The NCC provides Deemed-to-Satisfy Provisions for compliance and installation of the various types of insulation. The insulation should be installed in the Hebel High Rise Facade system, such that it forms a continuous barrier to contribute to the thermal barrier. All insulation installed in a Hebel High Rise Facade System must comply with: AS/NZS4859.1; or AS2464.3 for loose fill insulation.

HEBEL HIGH RISE FACADE SYSTEM

One of the primary design objectives in planning a building is to provide a cost effective comfortable living / working environment for the building's inhabitants. Exploiting the inherent thermal mass and insulation qualities of Hebel Autoclaved Aerated Concrete (AAC) enables the designer to achieve this objective.

Several comparative studies have been conducted to investigate the benefits of incorporating AAC walls in place of conventional wall systems. A common trend was the lower heating and cooling energy consumption and smaller mechanical equipment required to maintain a comfortable living environment, especially in regions of mainly cold weather. The excellent performance was the result of the three characteristics – thermal mass, thermal insulation and the airtightness of the construction.

The level of insulation provided in a wall is determined by the required Total R-value. The higher the required Total R-value the greater the insulation provided.

AIRTIGHTNESS

Thermal performance can be influenced by many factors. Most of these are related to the design decisions and properties of the adopted materials.

Construction practices can also significantly affect the performance, for example with poor sealing which results in drafts. The tight construction tolerances of AAC provide a wall with low air infiltration rate. Testing at the CSIRO (Test Report DTM327) on Hebel blockwork with thin bed adhesive joints has determined an air infiltration rate of 0.3L/s (0.014% of internal volume). For panel construction with fewer thin bed adhesive joints, a rate less than this could be achieved. The air infiltration of the Hebel High Rise Facade System is also dependant on the wall wrap, plasterboard linings and internal seals.

WALL WRAP

As well as controlling condensation and acting as an air barrier, wall wrap can be used to significantly improve the thermal insulation and energy efficiency performance of a building solution. Wall wrap layers can alter the performance of the cavity by providing a stagnant column of air. The wall wraps specified for the Hebel High Rise Facade System (Bradford Enviroseal™ RW, Bradford Enviroseal™ CW and DuPont Tyvek Home Wrap) are vapour permeable building wraps. These wall wraps must be designed and installed in accordance with AS/NZS 4200 Part 1 - materials and Part 2 - installation.

Figure 2.6.1 ABCB Climate zone map: Australia wide

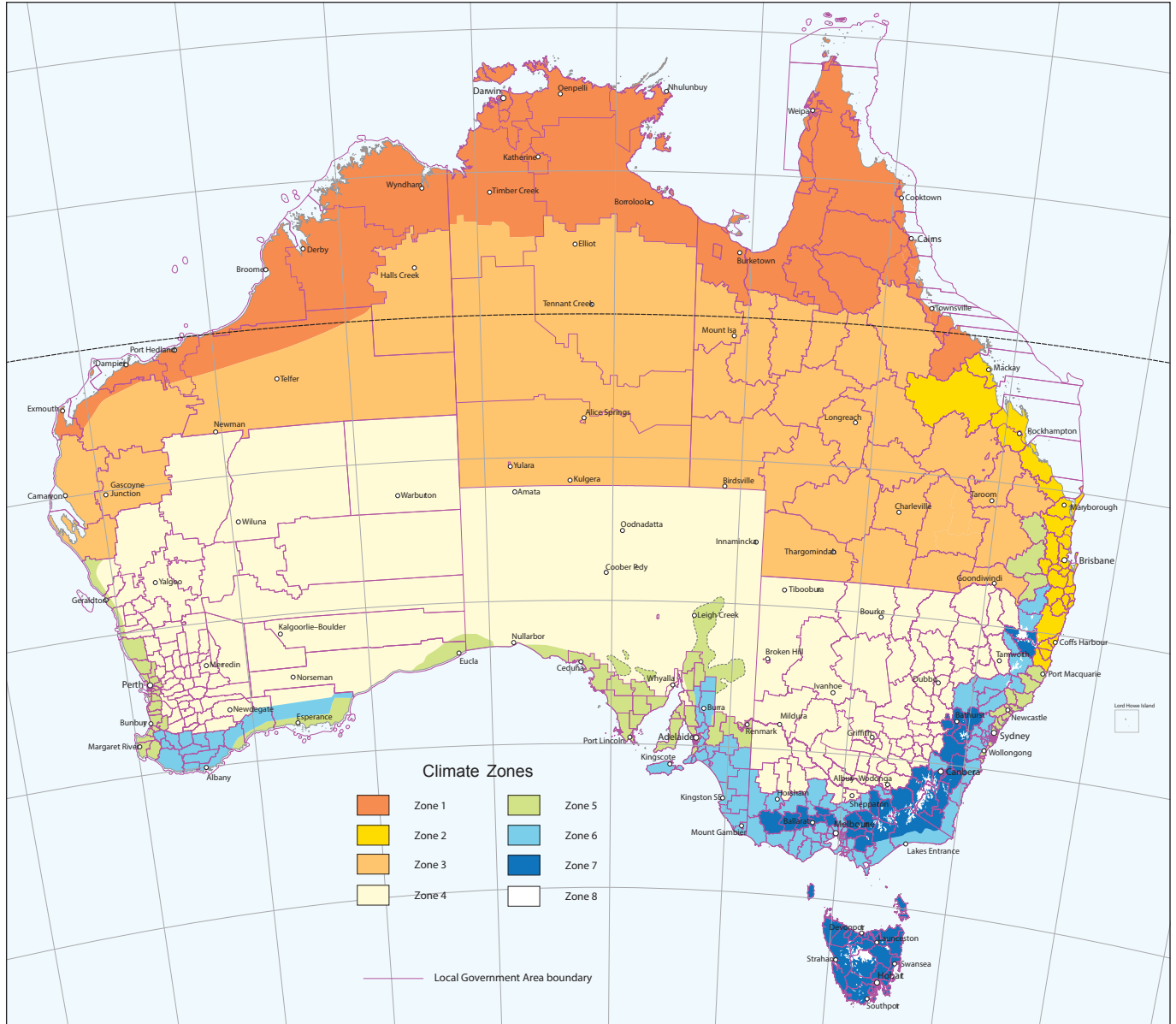

Table 2.6.1 NCC 2019 Vol1 – Minimum wall total R-Value - wall area 80% or more of glazing construction area

Climate zone	Class 2 common area, Class 5, 6, 7, 8 or 9b building or a Class 9a building other than a ward area	Class 3 or 9c building or Class 9a ward area
2	1.4	1.4
3	1.4	3.3
4	1.4	2.8
5	1.4	1.4
6	1.4	2.8
7	1.4	2.8
8	1.4	3.8

Note that the Hebel Facade Systems are not to be used in Climate Zone 1

Table 2.6.2 Hebel High Rise Facade System energy efficiency

System reference	System components	Total R,m2.K/W	
		Winter	Summer
Hebel1347, Hebel1349	Outdoor air film, coating system, Hebel PowerPanel 75mm, 50mm air space, Bradford Enviroseal™ or DuPont™ Tyvek® HomeWrap®, R2.5 Bradford Gold Wall Batts (90mm, 10.4kg/m3), 13mm plasterboard, indoor air film	R3.08	R2.93
Hebel1536	Outdoor air film, coating system, Hebel PowerPanel 75mm, 50mm air space, Bradford Enviroseal™ or DuPont™ Tyvek® HomeWrap®, R2.5 Bradford Gold Wall Batts (90mm, 10.4kg/m3), 1x16mm Gyprock Fyrcek plasterboard, indoor air film.	R2.97	R2.83
Hebel1537	Outdoor air film, coating system, Hebel PowerPanel 75mm, Bradford Enviroseal™ or DuPont™ Tyvek® HomeWrap®, R2.5 Bradford Gold Wall Batts (90mm, 10.4kg/m3), 2x13mm Gyprock Fyrcek plasterboard, indoor air film.	R3.05	R2.91
Hebel1538	Outdoor air film, coating system, Hebel PowerPanel 75mm, Bradford Enviroseal™ or DuPont™ Tyvek® HomeWrap®, R2.5 Bradford Gold Wall Batts (90mm, 10.4kg/m3), 2x16mm Gyprock Fyrcek plasterboard, indoor air film.	R3.10	R2.96

Stated R-values in Table 2.6.2 have been provided by James Fricker: calculations 107PPW001 to 107PPW00212 dated 05/07/2019.

2.7 DURABILITY

The durability of the Hebel High Rise Facade System can be enhanced by periodic inspection and maintenance. Inspections should include examination of the coatings, flashings and seals. Facade finishes and sealants must be maintained in accordance with the manufacturer's recommendations. Any cracked and damaged finish or sealants, which would allow water ingress, must be repaired immediately by recoating or resealing the effected area. Any damaged flashings or panels must be replaced.

The drainage openings (pressure equalisation slots) do not allow the external environment to circulate in the cavity space where the top hats are located. The cavity space is a stagnant column of air not subject to air circulation.

The durability of the system can also be increased by using Class 4 fixings throughout, additional treatment of steelwork and by painting all exposed sealants to the sealant manufacturer's recommendations.

COASTAL AREAS

The Hebel High Rise Facade System can be used in coastal areas with additional precautions to ensure salt does not build up on the surface of the wall. For buildings which are 300m to 1000m from a shoreline or large expanse of salt water, one of the following is required:

- all walls must be sufficiently exposed from above so that rain can perform natural wash-down of the wall; or
- walls which are protected by soffits above must be washed down twice per year, to remove salt and debris build-up, particularly at the joints.

For buildings up to 1000m from the shoreline as defined above, the Hebel facade wall system must be constructed as follows:

- The Hebel facade system must be constructed as a face sealed system. Therefore, no pressure equalised slots are to be installed to ensure the cavity remains sealed.
- The screws fixing the Hebel Powerpanels to the tophats must be countersunk into the panel by at least 5mm with the hole filled with either Hebel Patch or Hebel Adhesive.
- Class 3 screws are suitable to be used as the cavity is closed and remains sealed.

Where the Hebel facade system is constructed within 300m from the shoreline, the installation of the coatings is critical for weathertightness. The coating system is the key barrier to ensuring no water ingress occurs.

SEVERE MARINE OR HEAVY INDUSTRIAL REGIONS

For regions classified as severe marine or heavy industrial, CSR Hebel recommends that the designer ensures steelwork and AAC products have adequate protective systems to ensure durability is maintained. The designer can refer to AS4312 for detailed information on corrosion.

HEBEL POWERPANEL

Hebel PowerPanel has many properties which make it a very durable product:

- Hebel Powerpanels will not rot or burn, is not a food source for termites, and is unaffected by sunlight
- Hebel Powerpanels are not adversely affected over normal temperature ranges.

LIGHTWEIGHT (COLD FORMED) STEEL SUPPORT FRAMING

The NCC Volume 2, Part 3.4.2 presents 'Acceptable Construction Practice' Performance Requirements for the protection of the steel frame from corrosion. These requirements consist of minimum protective surface coatings with restrictions on the location of the building and exposure condition of the steel frame.

For the Hebel High Rise Facade System, the steel framing is considered to be located within the building envelope, hence the requirements are as follows:

- where the steel frame is within the building envelope, in locations
- more than 300m from breaking surf, or
- not in a heavy industrial area

the steel frame must have a minimum coating class in accordance with AS1397 of Z275 (275 grams of zinc per square metre) or AZ150 (150 grams of aluminium/zinc per square metre).

The NCC describes the building envelope as the space in the building where the steel frame does not have direct contact with the external atmosphere, other than for normal ventilation purposes. An example of such locations, are frames in masonry veneer construction.

3.1 INSTALLATION SEQUENCE: FACADE WITH VISIBLE SLAB EDGE

Facade with visible slab edge installation sequence

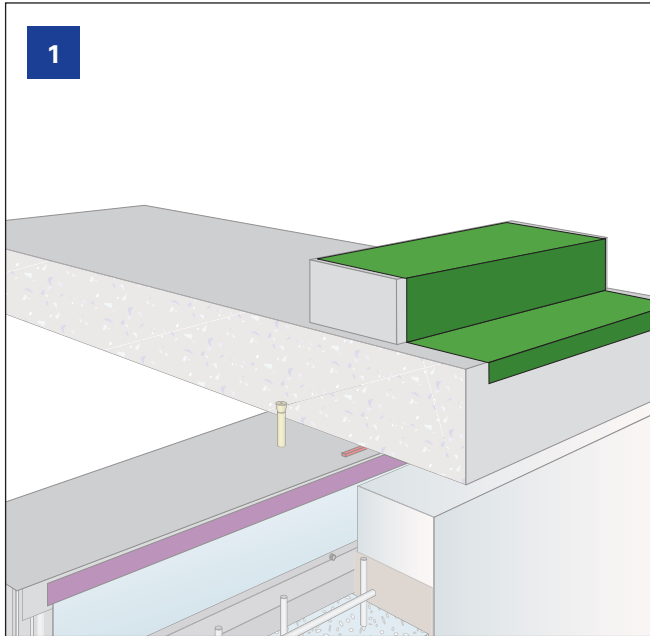

Apply waterproof membrane to hob and slab edge/rebate.

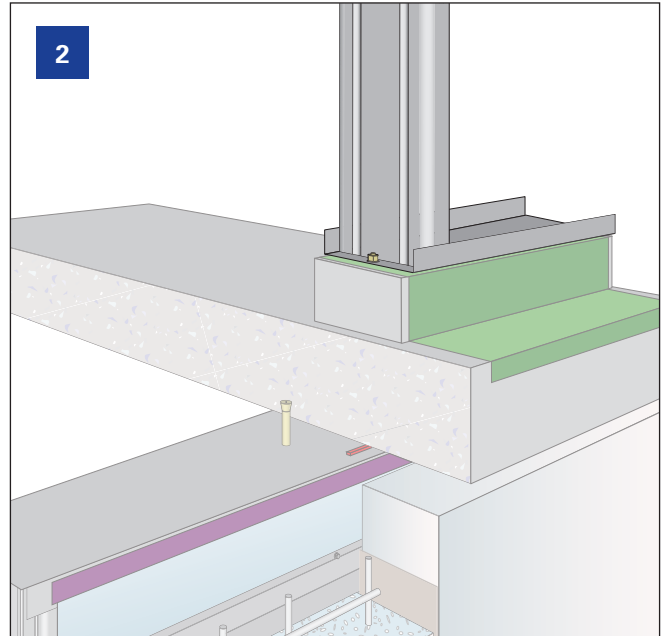

Install Rondo steel stud frame.

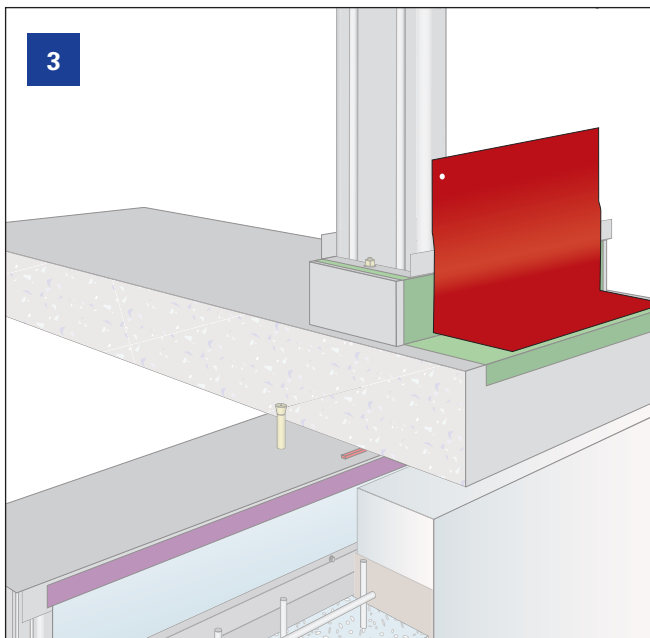

Install DPC / flashing and fix to frame. Height of flashing to be a minimum 100mm higher than bottom plate.

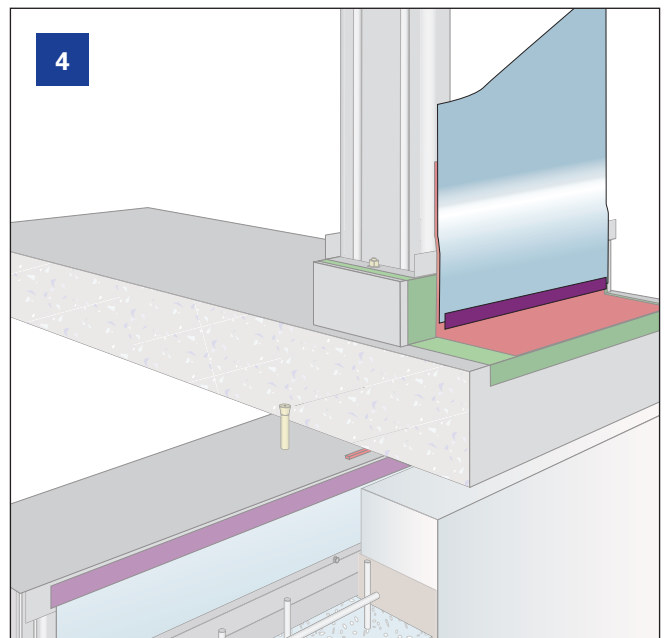

Install wall wrap taping off to flashing, stud head track and any concrete elements.

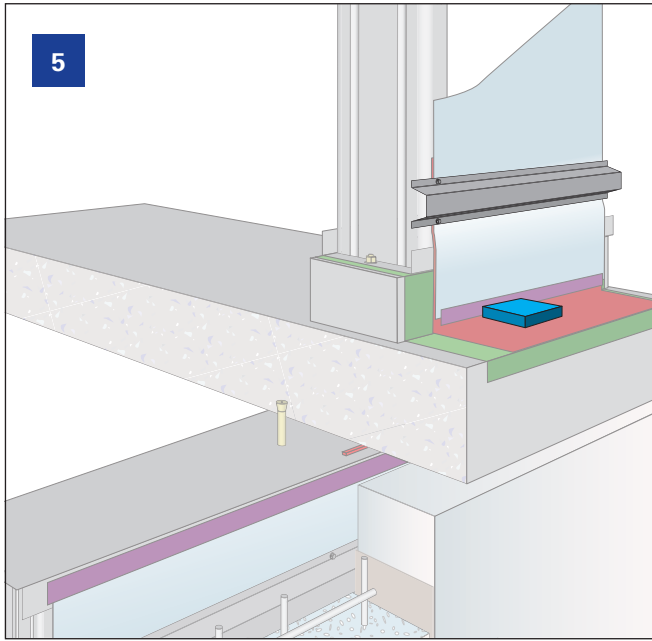

Step 5(i): Install Hebel Facade top hats and cavity baffles. Cavity baffles are fixed vertically at all major corners of building.

Step 5(ii): Place non compressible non-combustible packer at each end of each PowerPanel ie. minimum 2 per panel.

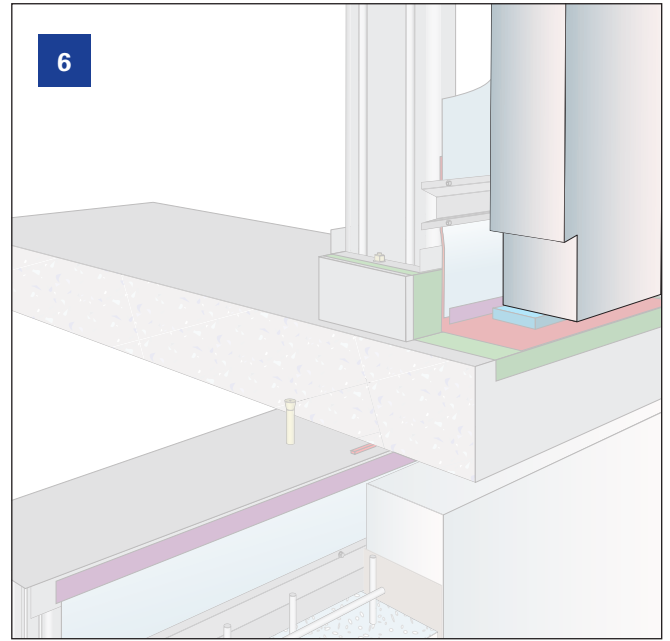

Install PowerPanel with pressure equalisation slots which should be installed proud of the face of the panel to allow for thickness of render.

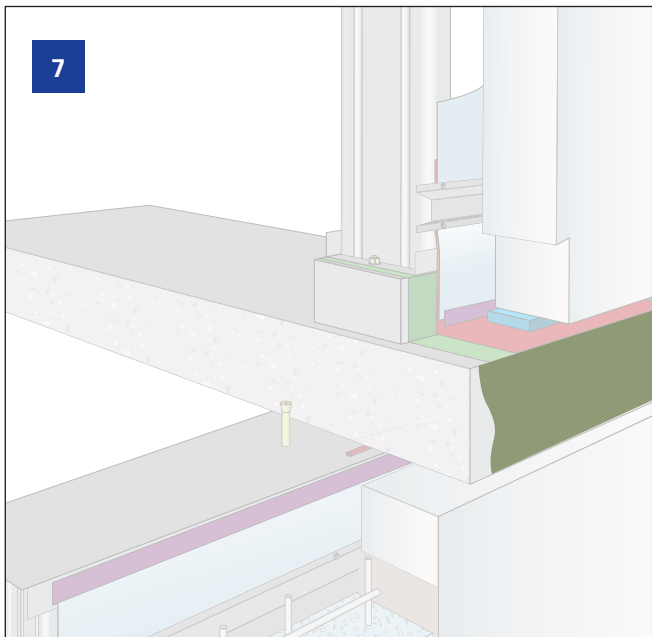

Install Dulux AcraLite to flush fill the slab edge recess level across panels .

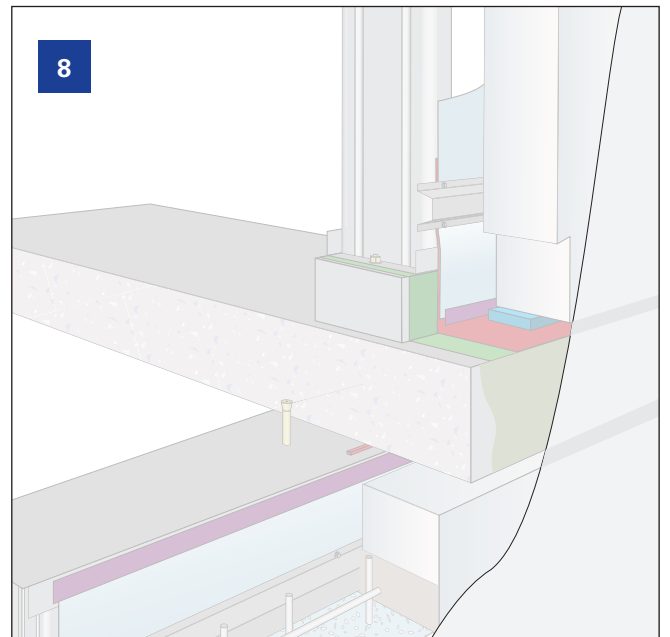

Apply Dulux AcraTex AcraPatch HighBuild levelling layer level across panel and joints.

Note: Fire sealant can be installed prior to AcraPatch layer provided render is removed back to sealant surface and top up sealant applied before final top coat.

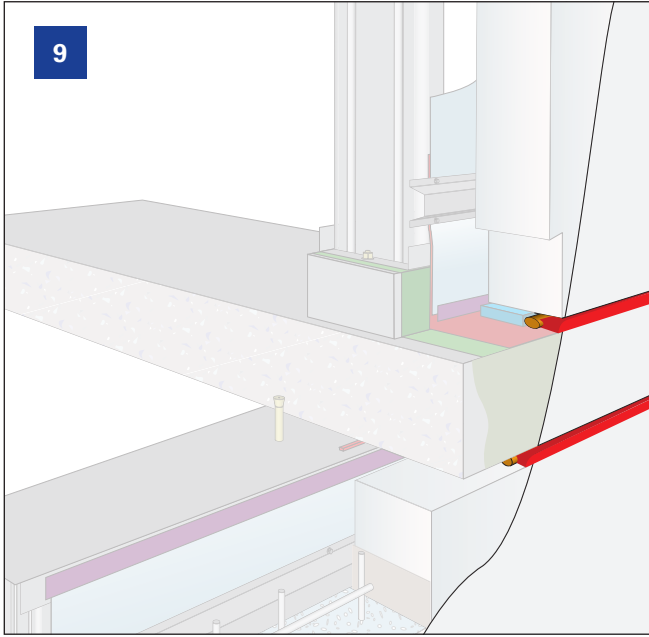

9
 Accurately mark out and re-cut horizontal expansion joints top and bottom of slab edges ensuring slab and panel are independent. Install approved sealant including backing rod (gasket) as per supplier instructions.

Note: Backing rod (gasket) and sealant (fire rated as required) to adhere and be compatible with external coating system.

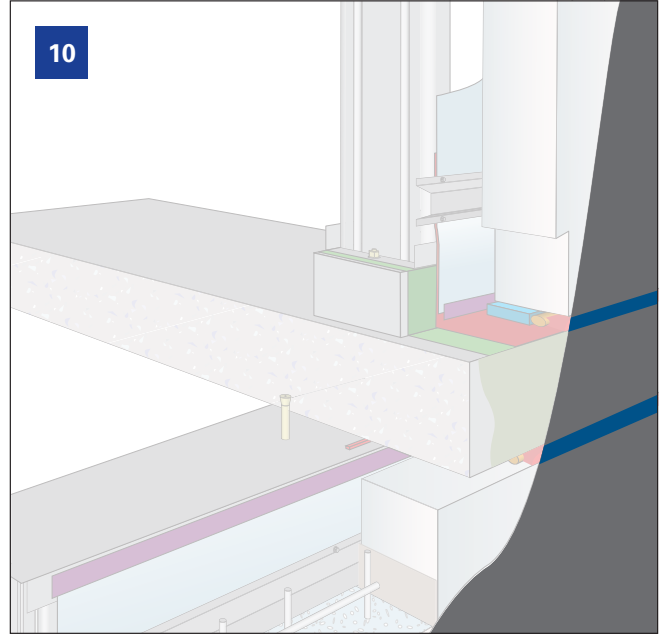

10
 Mask cured control joint sealant with 6mm masking tape. Apply Dulux AcraTex AcraSkin texture layer by medium texture roller. Remove masking before coating dries. Coating system texture layer must NOT bridge control joints.



11
 Apply final weatherproofing topcoat layer of AcraSkin by nap roller over the entire area including the control joints providing colour uniformity across the panel and joints.

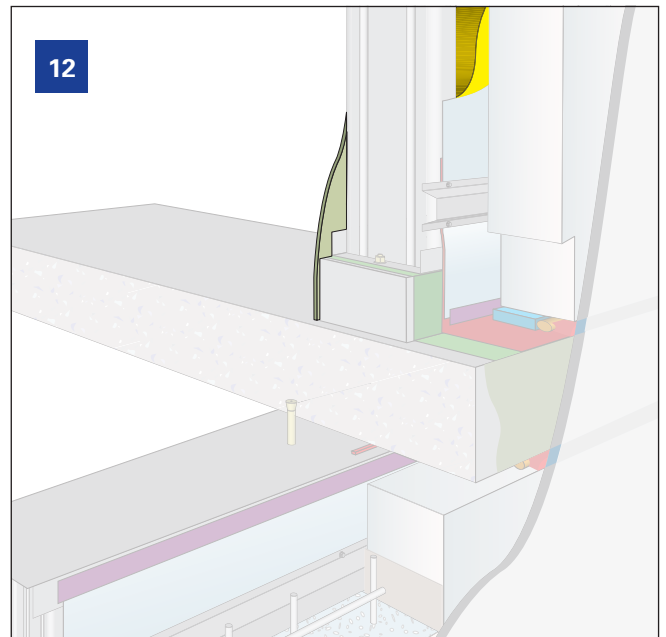

12
 Install Bradford insulation and line internally with Gyprock plasterboard as per the system requirements.

3.2 INSTALLATION SEQUENCE: FACADE WITH HIDDEN SLAB EDGE

Facade with hidden slab edge installation sequence

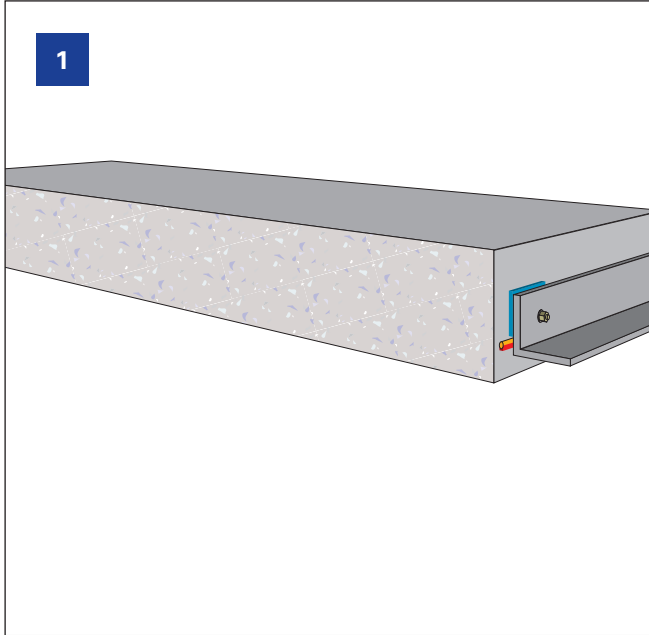

1
Install shelf angle. Install backing rod (gasket) and sealant between the underside of shelf angle and slab. If Hebel panels below have been installed prior to the shelf angle being fixed to slab edge, apply a continuous bead of fire rated sealant along the top edge of the shelf angle and in slotted holes of angle.

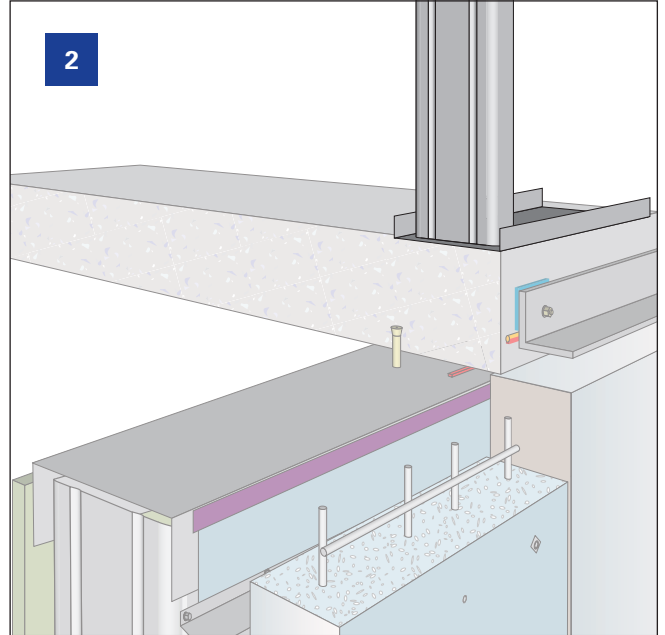

2
Install Rondo steel stud frame.

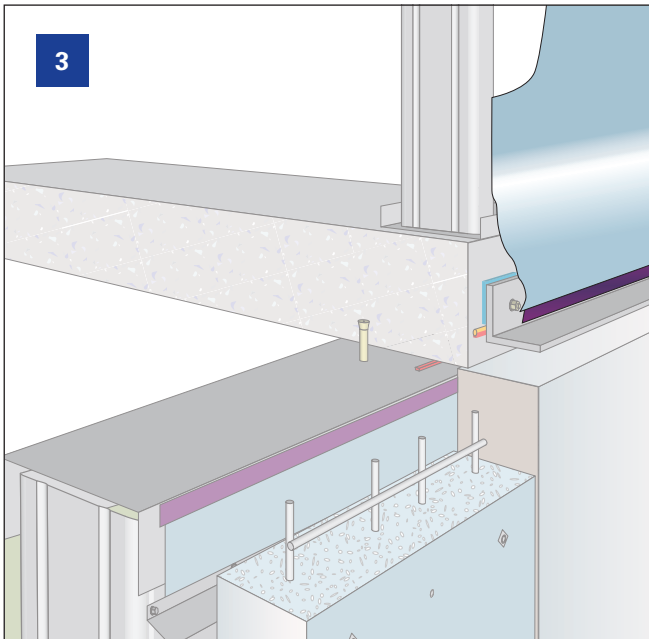

3
Install wall wrap taping off to shelf angle, stud track and any concrete elements.

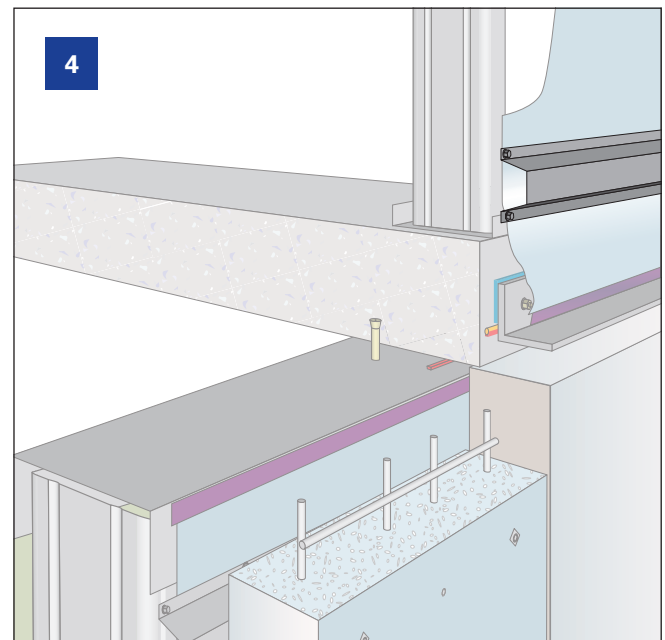

4
Install Hebel Facade top hats and cavity baffles. Cavity baffles are fixed vertically at all major corners of the building.

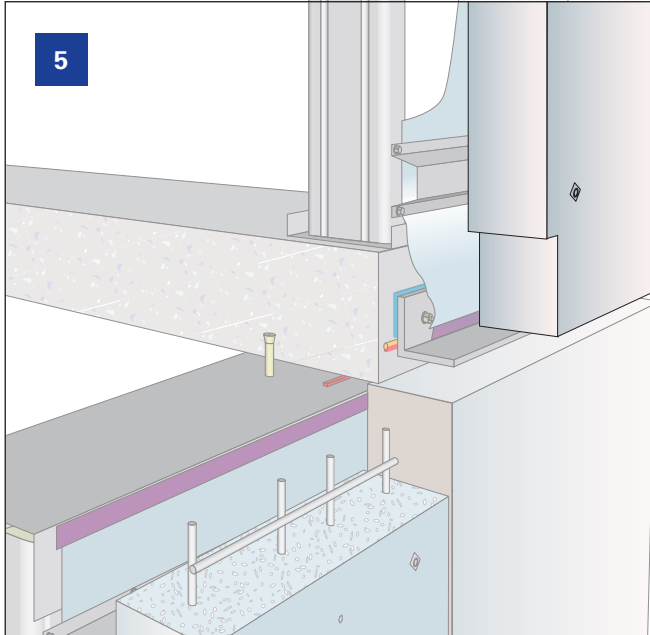

5
Install PowerPanel with pressure equalisation slots which should be installed proud of the face of the panel to allow for thickness of render.

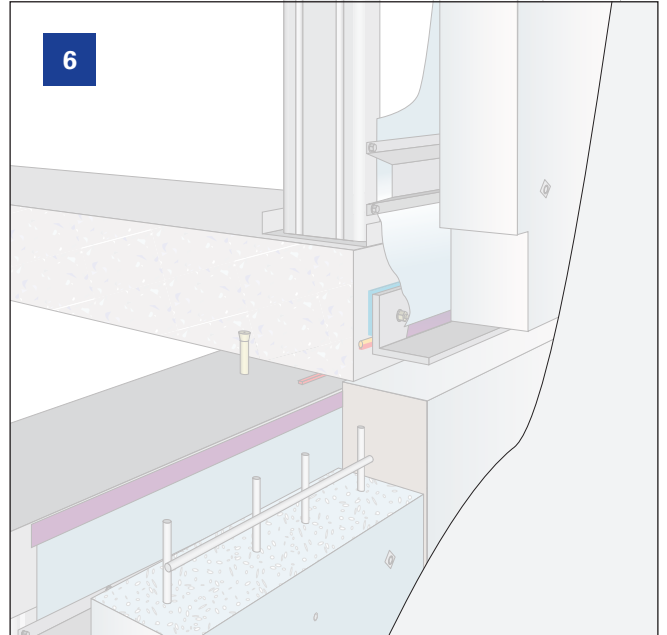

6
Apply Dulux AcraTex AcraPatch HighBuild levelling layer across panel and joints.

Note: Fire sealant can be installed prior to AcraPatch layer provided render is removed back to sealant surface and top up sealant applied before final top coat.

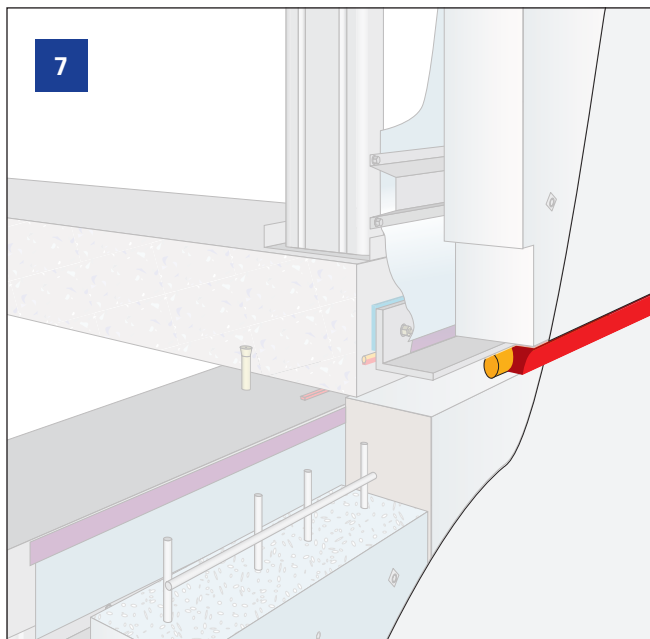

7
Accurately mark out and re-cut horizontal expansion joints. Install approved sealant including backing rod (gasket) as per supplier instructions.

Note: Backing rod (gasket) and sealant (fire rated as required) to adhere and be compatible with external coating system.

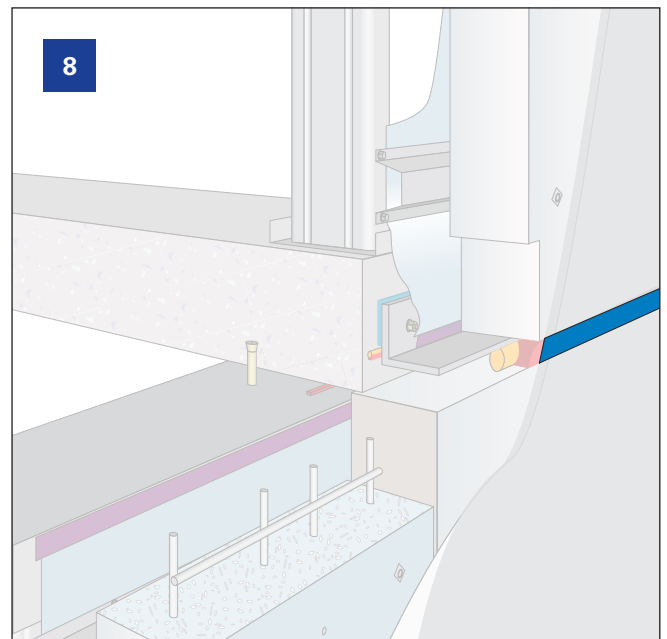

8
Mask cured control joint sealant with 6mm masking tape. Apply Dulux AcraTex AcraSkin texture layer by medium texture roller. Remove masking before coating dries. Coating system texture layer must NOT bridge control Joints.

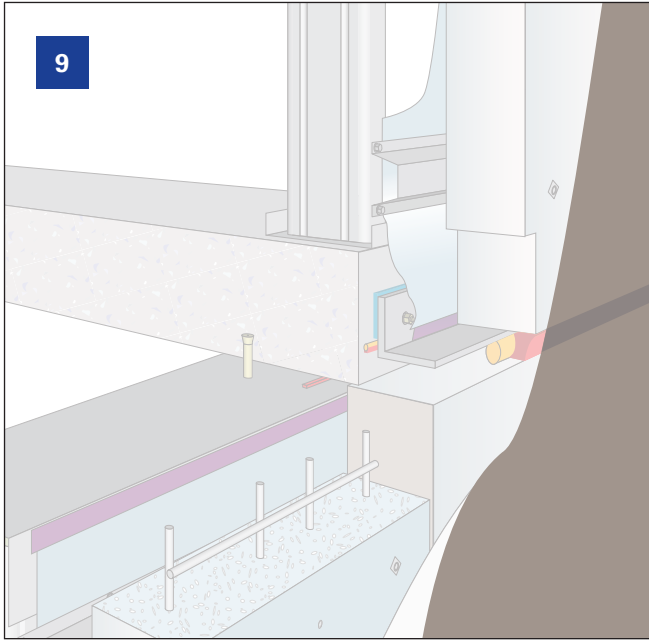

Apply final weatherproofing topcoat layer of AcraSkin by nap roller over the entire area including the control joints providing colour uniformity across the panel and joints.

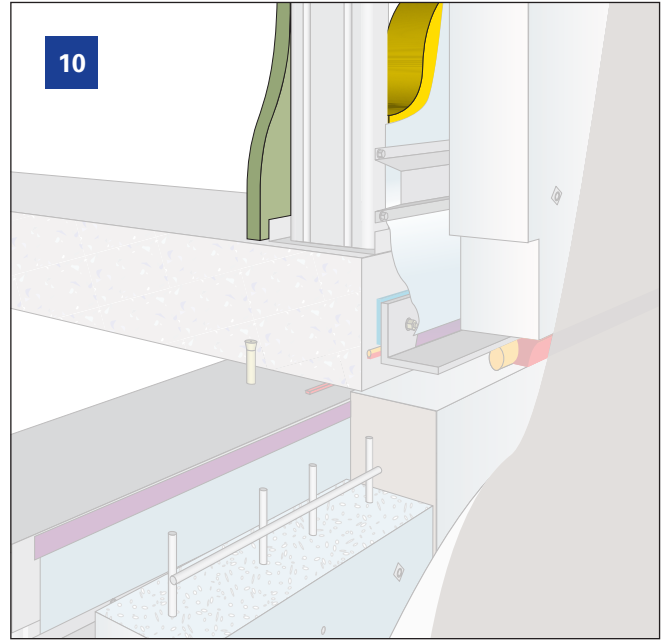

Install Bradford insulation and line internally with Gyprock plasterboard as per the system requirements.

3.3 INSTALLATION

It is the responsibility of the architectural designer and engineering parties to ensure that the details in this design and installation guide are appropriate for the intended application.

The recommendations of this guide are formulated along the lines of good building practice, but are not intended to be an exhaustive statement of all relevant data. Hebel accepts no responsibility for or in connection with the quality of installation of the Hebel High Rise Facade system when installed.

SCAFFOLDING

Should be fixed (where possible) to the structure at the slab edge, balconies or window openings. It is recommended to avoid passing through the Hebel wall to concrete columns/slabs as this will require patching afterwards and can show in final finish.

SETTING OUT & POSITIONING OF WALLS

Before commencing any installation work, ensure the work area is clean and tidy. Mark out the location of the walls, doors, windows, control joints etc. Ensure the panel widths are a minimum 270mm.

WATERPROOFING MEMBRANES

Once the work area is cleaned and marked out, apply waterproof membrane coating to all slab steps, rebates and hobs. A waterproof membrane is not required if the Hebel Hidden Slab Edge detail is used. All waterproof coating membranes are to be applied in accordance with the coating membrane manufacturer's specifications and details.

HEBEL SHELF ANGLE

The shelf angle is required in situations where the Hebel PowerPanel is located in front of the slab. The shelf angle acts as a partial support to rest the panel on during the installation of the panel. In addition, the shelf angle acts as a flame and smoke barrier between floors. Shelf angle butt joints must be fully sealed with a suitable fire rated sealant. Refer to Construction details section for all shelf angle sealant details.

MINIMUM ANCHOR DETAIL OPTIONS

- M12 Hilti HVU galvanised chemical anchors are required at no more than 900mm centres (for embedment depth of 110mm)
- M10 Hilti HVU galvanised chemical anchors are required at no more than 450mm centres (for embedment depth of 90mm)
- Hilti HSA-F M10 galvanised mechanical anchors are required at no more than 600mm centres (for embedment depth of 50mm into uncracked 150mm min. concrete slab).

Note: Minimum edge distance 70mm to the underside of slab.

STEEL STUD FRAMEWORK

Rondo or approved equivalent steel stud framework must be installed in accordance with the manufacturer's or project engineer's specifications. Rondo cleats are required on studs within 150mm of deflection track joints and on jamb studs. It is the responsibility of the builder to obtain the following documentation:

- stud framing design (prior to commencing installation of the facade system)
- certification of frame installation to frame manufacturer's design or project engineer's specification.

It is recommended that the same contractor installs the steel stud framing, top hats, sarking and Hebel panels to eliminate conflicting issues such as misalignment and installation warranty.

WALL WRAP

The wall wrap should be installed in accordance with the manufacturer's or project consultant's specifications. Each successive level should overlap the bottom level by a minimum of 150mm and be fully sealed with appropriate tape. Joints between successive levels should be fully sealed with an appropriate sealant or tape as required. Wall wrap must be taped off to concrete elements. Provide reinforcement where wrap folds around sharp elements such as ends of top hats.

CAVITY BAFFLES

Cavity baffles must be installed vertically at every major external corner of the building to break up the cavity and pressure each elevation independently. This will depend on the design of the building incorporating columns in the corners of the building or full height windows and doors. Refer to Figure 1.6 page 131.

HEBEL FACADE TOP HAT

Top hats should be cut to size before securing them to steel studs. At control joints the top hats must be discontinuous. For number, location, spacing and fixing of top hats, refer to the project specifications. Extra top hats may be required around penetrations (eg kitchen ducts) to support the Hebel panels.

RONDO ADJUSTABLE TOP HAT BRACKET ASSEMBLY

Rondo also supplies an adjustable top hat bracket to allow fixing of top hat to concrete column. It also helps correct misalignment of the main concrete structure.

HEBEL POWERPANEL

Hebel PowerPanel should be sized and prepared before installing the packer or mortar. The panels can be trimmed onsite using a circular saw equipped with diamond tipped cutting blade and a portable dust extraction unit.

All loose AAC particles should be brushed off the panel with a rough broom. Steel reinforcement that is exposed on cut panels must be coated with a liberal application of Hebel Anti-Corrosion Protection Paint immediately following cutting of panel. Panels can be cut down to a minimum of 270mm wide which ensures two longitudinal bars of reinforcing within the panel. It is good practice for the cut side of the panels to be placed in adhesive joint, and not on end of the wall or adjacent to windows or doors.

Any minor damage and chips to the panels must be repaired using Hebel Patch. When the preparation of the panel is complete, locate the panel into its final position. Then secure the panel to the top hats with 3 x #14-10x100mm bugle head screws per 600mm wide panel per top hat.

Outer screws should be located 50mm minimum and a 100mm maximum from the vertical edges of the panel.

Screwing of panels to top hats is always done from the outside. When the panel is secured in place, apply Hebel Adhesive to the panel edge abutting the next wall panel to be installed.

Repeat the installation process until the wall is complete.

HEBEL ADHESIVE

Hebel Adhesive is applied evenly to the panel with a trowel. When the panels are pushed together, the joints are to be 2-3mm thick. Sufficient pressure must be applied to the panels when gluing to ensure the adhesive is fully bedded across the joint. Scrape off any excess adhesive protruding from the joints once the wall is installed. Adhesive is to be mixed to the proportions and consistency as per the instructions on the bag.

PRESSURE EQUALISATION SLOTS

Pressure equalisation slots are required on all facades (except within 300m of breaking surf) to allow the pressure to be the same within the cavity as the outside. They can be installed at control joints and no greater than 3 metre spacings by cutting the panel to the dimensions of the slot. Pressure equalisation slots are to be installed at the base of the panels. These must be installed prior to any coating. These slots are to be kept open and not rendered or painted over.

WINDOWS

Sills to be cut on an angle of 15° minimum.

Sub-head, sub-sill and sub-jamb must bridge and seal the cavity preventing airflow to the cavity.

MOVEMENT JOINTS

All joint gaps which have been formed between panels, at the head and base or at abutments with other building elements should be caulked with appropriate backing rod (gasket), primer and sealant.

BRADFORD® INSULATION

Install Bradford insulation into the stud frame. The thickness of insulation provided should fully fill the cavity. If there is any gap in the insulation, the acoustic and thermal performance of the system may be adversely affected. Bradford handling and Design Guidelines should be followed.

GYPROCK® PLASTERBOARD

Plasterboard sheets must be cut to fit neatly and should not be forced into position. The plasterboard is to extend the full height of the steel stud framing, with gaps at top and bottom for sealant.

Plasterboard is to be fixed and installed to steel stud framing in accordance with Gyprock installation guidelines.

All movement joints and other gaps should be sealed off and finished neatly with project specified sealants. Installation of sealants must be carried out in accordance with the manufacturer's specifications.

Handling guidelines, design and installation guidelines and additional information on Gyprock Plasterboard are available from CSR Gyprock.

PENETRATIONS, ELECTRICAL, PLUMBING AND OTHER SERVICES

Installation of services and penetrations into Hebel facade walls should be carried out in an appropriate construction sequence. This will allow access to cavities, steel framed elements and Hebel panels, where services can be easily installed and neatly hidden.

CSR Hebel suggests the most appropriate time to carry out plumbing and cabling works is just before insulation and plasterboard are installed. The builder or project manager should confirm appropriate construction sequence for services and penetrations on a project-by-project basis.

Neat finishes for all penetrations is necessary to maintain the acoustic, thermal and fire integrity of the wall. Information regarding installation of services and penetrations is outlined in the various performance sections of this Hebel High Rise Facade Design and Installation Guide.

Where penetrations are required (e.g kitchen or bathroom exhaust), ensure that the distance from the top of the panel to the first top hat does not exceed 150mm. Additional top hat sections must be provided either side of penetration to support cut panel which can be installed vertically or horizontally depending on the space allowed.

FACADE & INTERTENANCY WALL JUNCTION

Install the facade wall system allowing for intertenancy panel to meet the back of the facade panel. A full length vertical damp proof course (DPC) is required with a fire and acoustic rated sealant between the facade panel and DPC and between DPC and wall wrap.

3.4 CONSTRUCTION DETAILS OVERVIEW

Table 3.4.1 Construction details overview

Construction details: visible and hidden slab edges	Visible slab edge head and base junctions with slab rebate	Figure 3.5.1.1	Page 44
	Base with hob detail	Figure 3.5.1.2	Page 44
	Hidden slab edge head and base junctions with shelf edge	Figure 3.5.1.3	Page 44
	Alternate shelf angle sealant details	Figure 3.5.1.4	Page 44
Stud frame, wall wrap and panel installation	Framing, top hat and wall wrap details	Figure 3.5.2.1	Page 45
	Top hat fixing to stud frame	Figure 3.5.2.2	Page 45
	PowerPanel fixing to top hats (visible slab edge)	Figure 3.5.2.3	Page 46
	Framing and top hat details at windows	Figure 3.5.2.4	Page 47
	PowerPanel and joint details at window (visible slab edge)	Figure 3.5.2.5	Page 47
Vertical junctions	External corner control joint	Figure 3.5.3.1	Page 48
	Option 1. External control joint at corner	Figure 3.5.3.2	Page 48
	Option 2. External control joint away from corner	Figure 3.5.3.3	Page 48
	External splayed corner control joint	Figure 3.5.3.4	Page 49
	Control joint	Figure 3.5.3.5	Page 49
	PowerPanel to concrete column/wall junction	Figure 3.5.3.6	Page 49
	Concrete column/wall junction behind Hebel facade	Figure 3.5.3.7	Page 49
	Internal corner control joint	Figure 3.5.3.8	Page 49
	Hebel facade to Hebel internal wall junction	Figure 3.5.3.9	Page 50
	Section AA Hebel facade to Hebel internal wall junction	Figure 3.5.3.10	Page 50
Windows and doors	Window head (sliding door similar)	Figure 3.5.4.1	Page 50
	Full height window head with shelf angle (sliding door similar)	Figure 3.5.4.2	Page 50
	Window jamb (sliding door similar)	Figure 3.5.4.3	Page 51
	Window sill	Figure 3.5.4.4	Page 51
Balconies	Base junction with double slab step	Figure 3.5.5.1	Page 52
	Base junction with drainage conduit	Figure 3.5.5.2	Page 52
Balcony blade walls	Framing, panel fixing and joint meshing details	Figure 3.5.6.1	Page 53
	Fixing details	Figure 3.5.6.2	Page 53
	Head and base junctions	Figure 3.5.6.3	Page 54
	Blade wall to Hebel facade junction	Figure 3.5.6.4	Page 54
Additional details	Parapet Capping	Figure 3.5.7.1	Page 55

3.5 CONSTRUCTION DETAILS

3.5.1 CONSTRUCTION DETAILS: VISIBLE AND HIDDEN SLAB EDGES

Figure 3.5.1.1 Visible slab edge head and base junctions with slab rebate

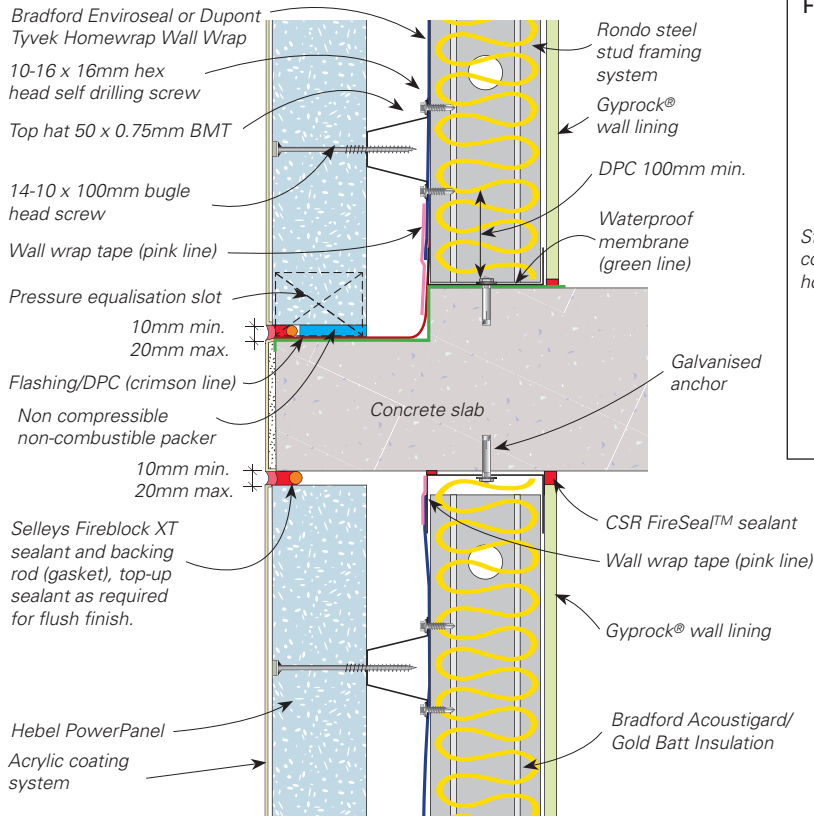
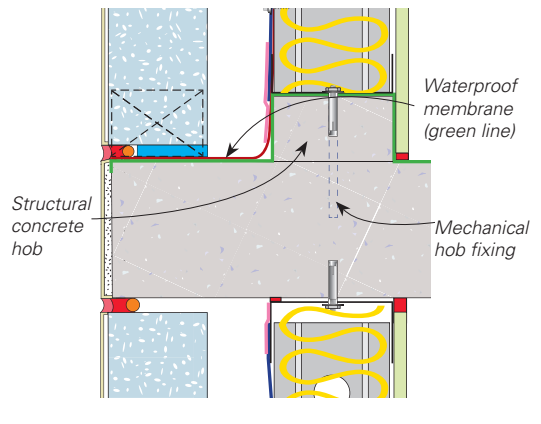

Figure 3.5.1.2 Base with hob detail



NOTE: Fireblock XT installation details*
 Min 10mm depth for 10mm wide joint,
 Min 16mm depth for 20mm wide joint
 * Applies to all sealant joints shown in construction details

Figure 3.5.1.3 Hidden slab edge head and base junctions with shelf edge

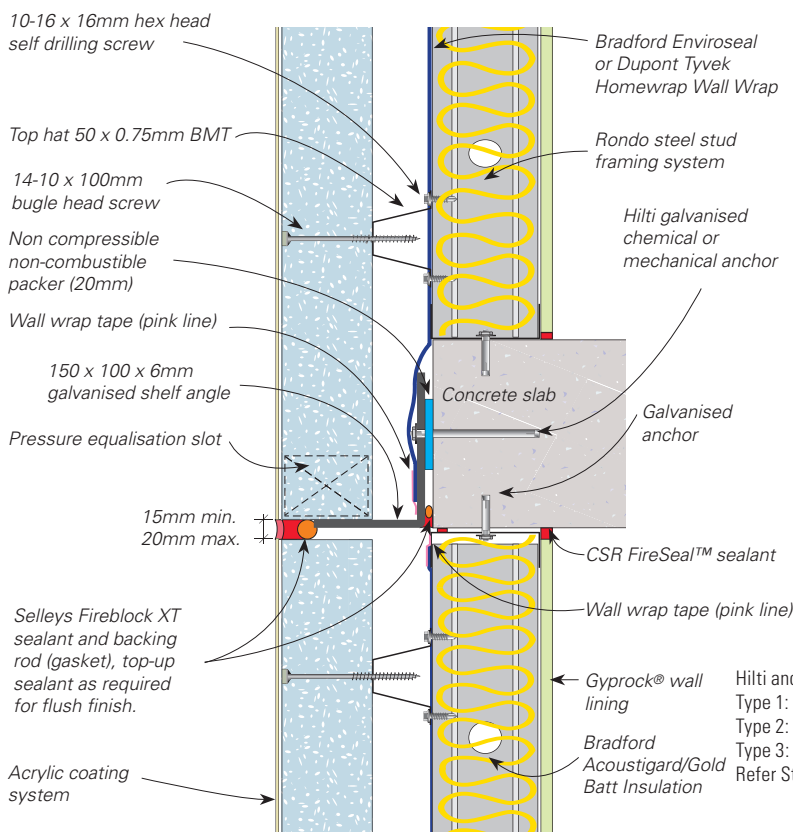
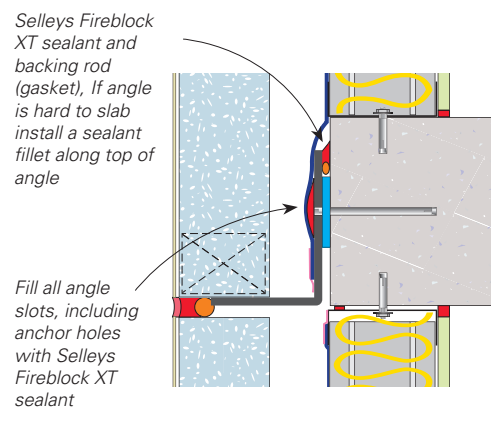

Figure 3.5.1.4 Alternate shelf angle sealant details



NOTE: Fireblock XT installation details*
 Min 16mm depth for 15-20mm wide joint
 * Applies to all sealant joints shown in construction details

Hilti anchor options
 Type 1: Galvanised chemical anchors at 900mm centres: M12 Hilti HVU
 Type 2: Galvanised chemical anchors at 450mm centres: M10 Hilti HVU
 Type 3: Galvanised mechanical anchors at 600mm centres: Hilti HSA-F M10
 Refer Structural Provisions section for min anchor edge distance and embedment

3.5.2 STUD FRAME, WALL WRAP AND PANEL INSTALLATION

IMPORTANT NOTE:

A frame design must be provided by the stud frame manufacturer prior to commencement of the Hebel Facade System installation. Periodic frame installation inspections and certification must also be undertaken by the frame manufacturer.

Figure 3.5.2.1 Framing, top hat and wall wrap details

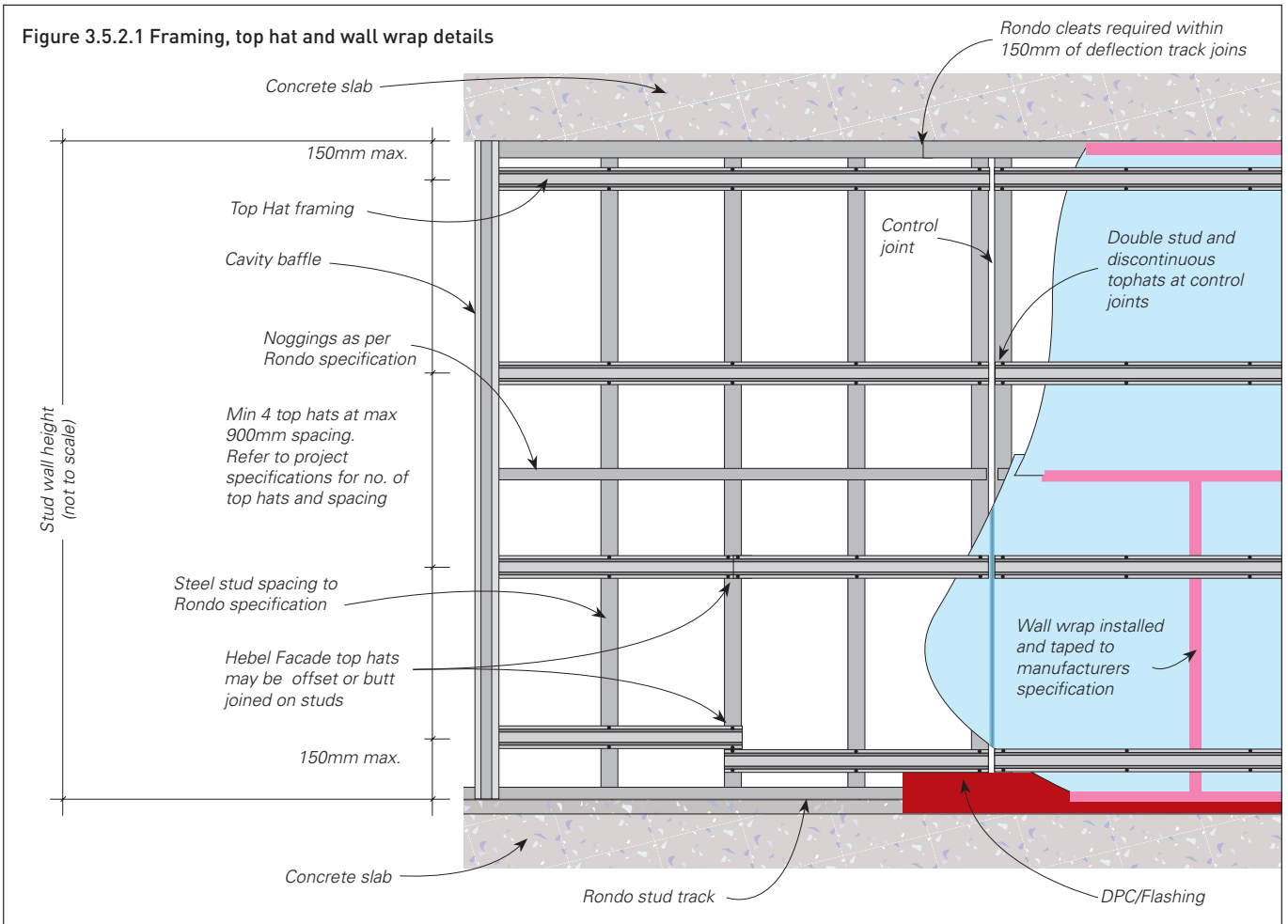

Fig 3.5.2.2 Top hat fixing to stud frame

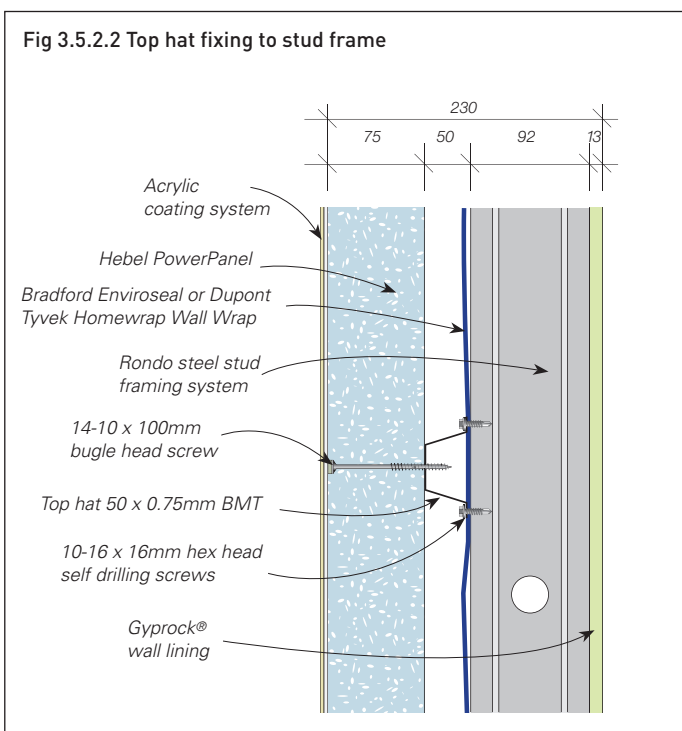
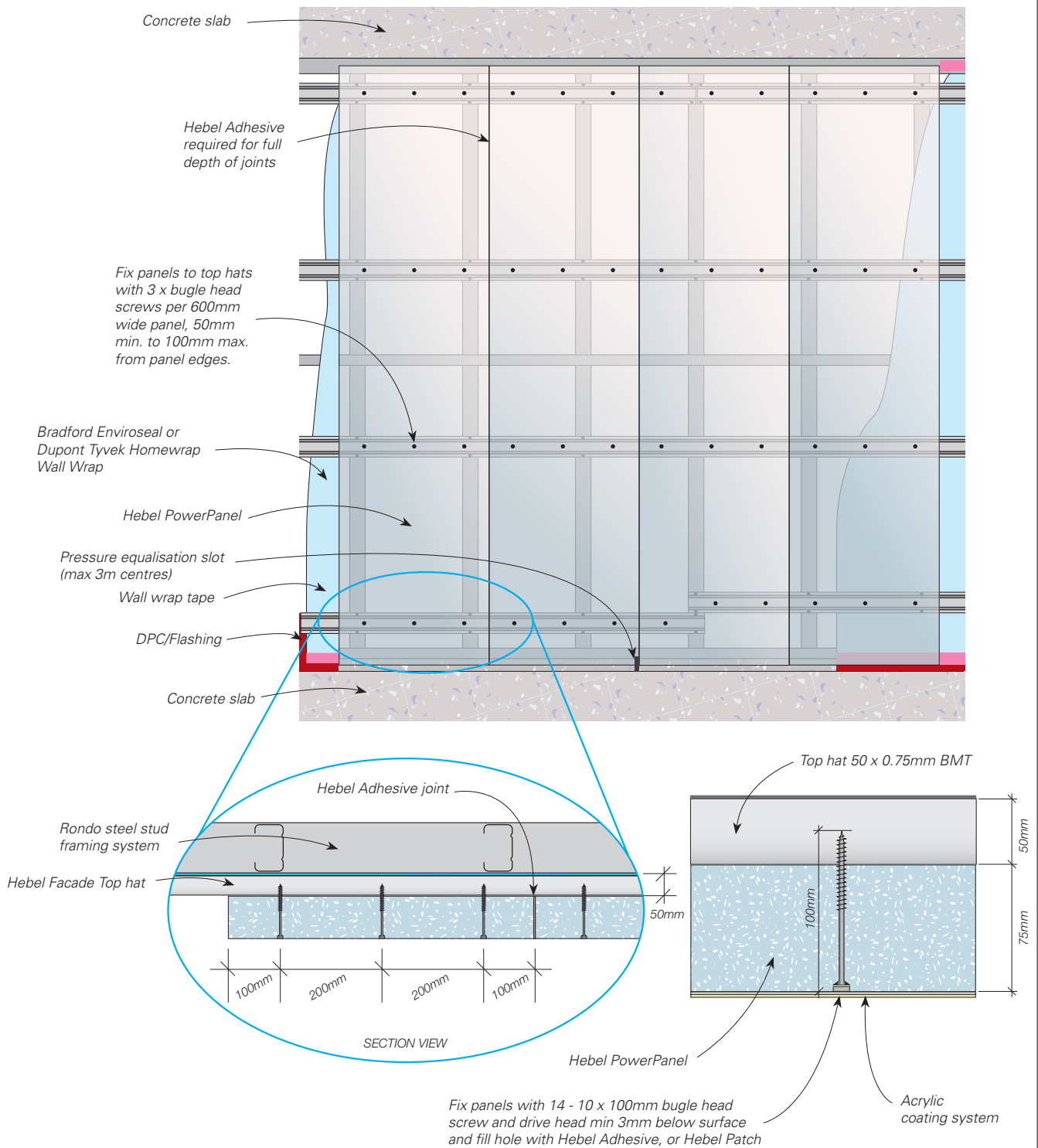

Figure 3.5.2.3 PowerPanel fixing to top hats (Visible slab edge detail shown)



IMPORTANT NOTE:

A frame design must be provided by the stud frame manufacturer prior to commencement of the Hebel Facade System installation. Periodic frame installation inspections and certification must also be undertaken by the frame manufacturer.

Figure 3.5.2.4 Framing and top hat details at windows

Note: Sliding door details sim

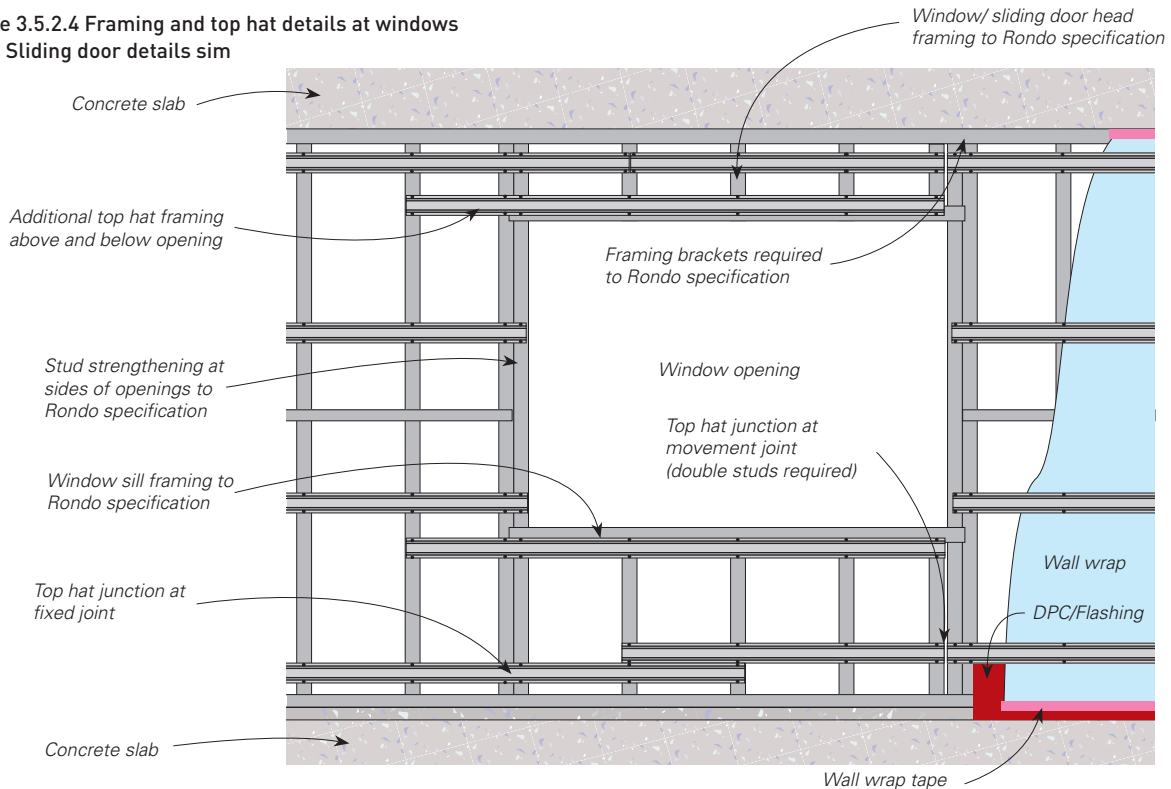
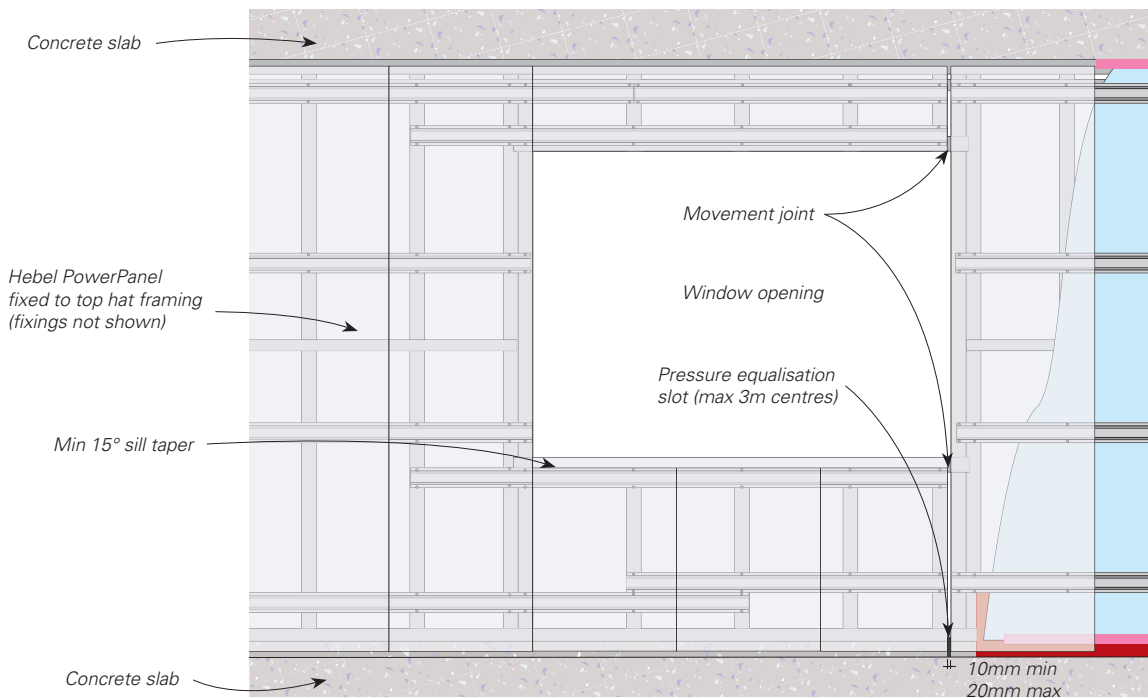

Figure 3.5.2.5 PowerPanel and joint details at windows (Visible slab edge detail shown)

Note: Sliding door details sim



NOTE: For major openings in the Hebel PowerPanel System for Facades, CSR Hebel recommends locating movement joints adjacent to the opening.

Control joints at door/window openings:

- Sliding door/window width \leq 2400mm – a control joint is to be provided to one side of the opening (minimum must be provided)
- Sliding door/window width $>$ 2400mm – control joints to both sides of the opening must be provided

3.5.3 VERTICAL JUNCTIONS

Figure 3.5.3.1 External corner control joint

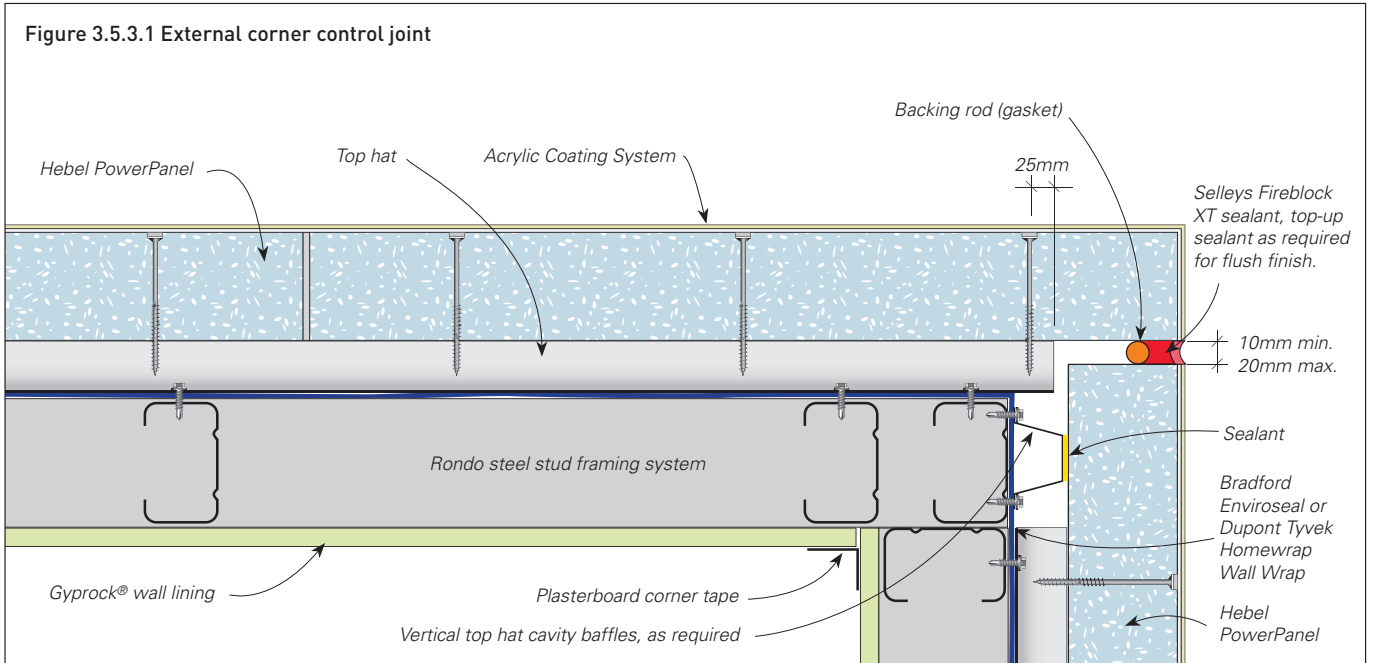

Figure 3.5.3.2 Option 1, external control joint at corner

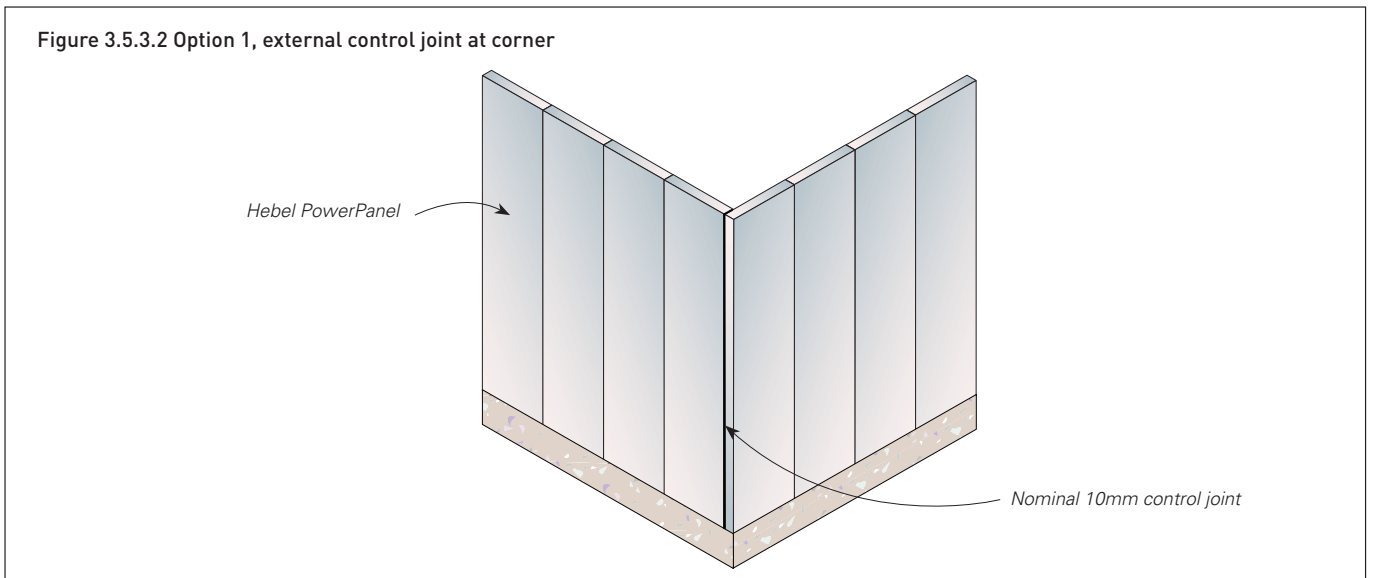
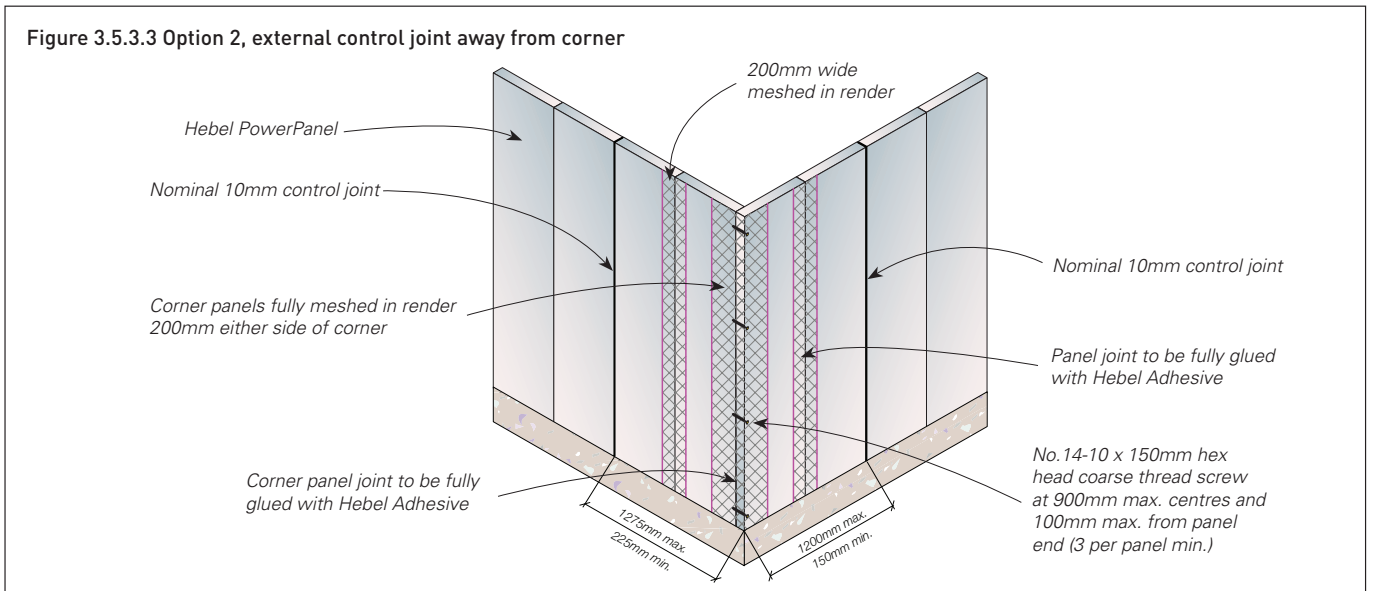

Figure 3.5.3.3 Option 2, external control joint away from corner



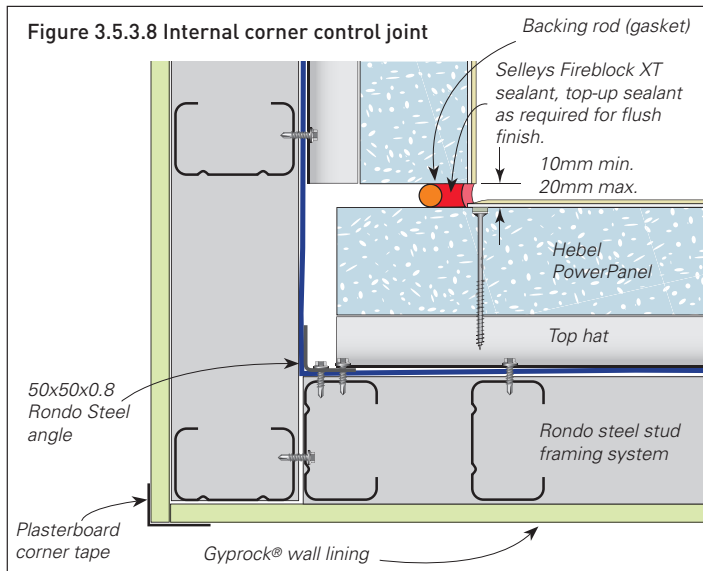
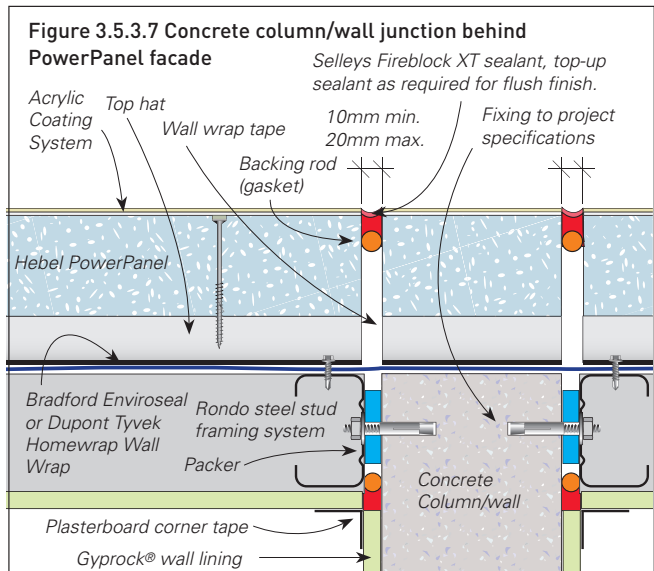
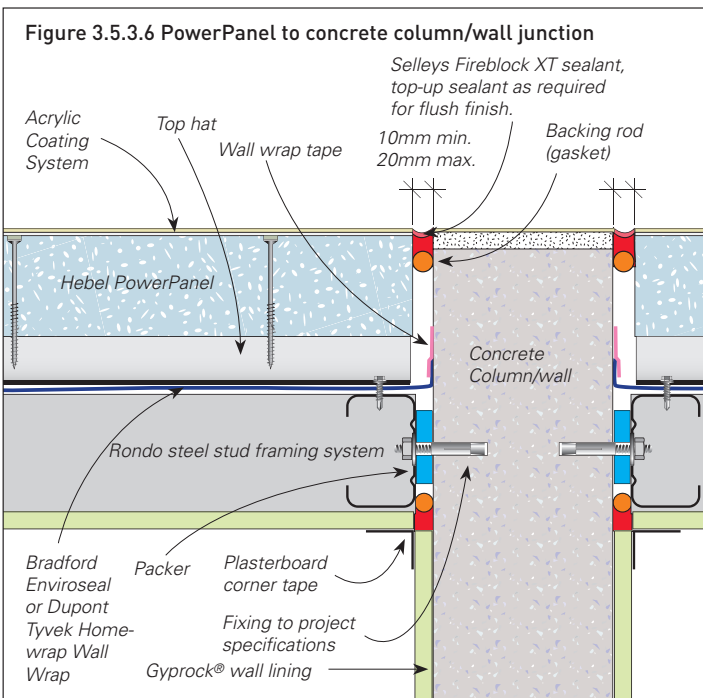
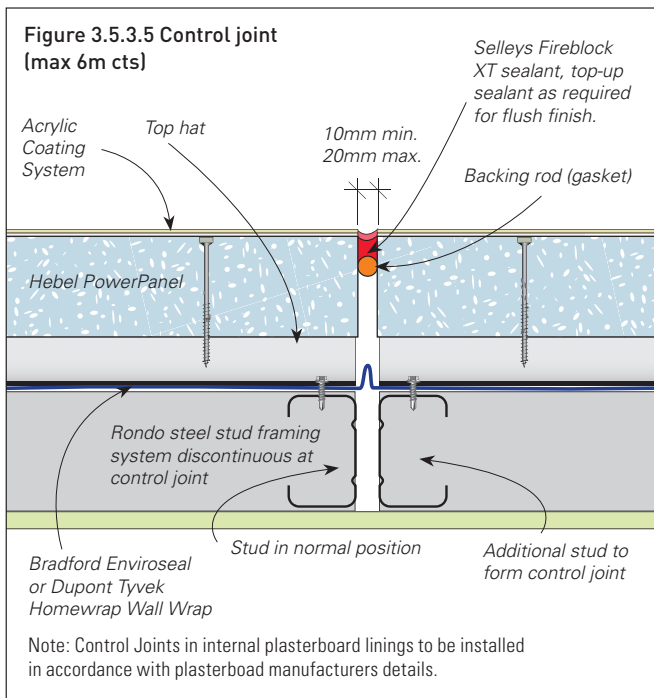
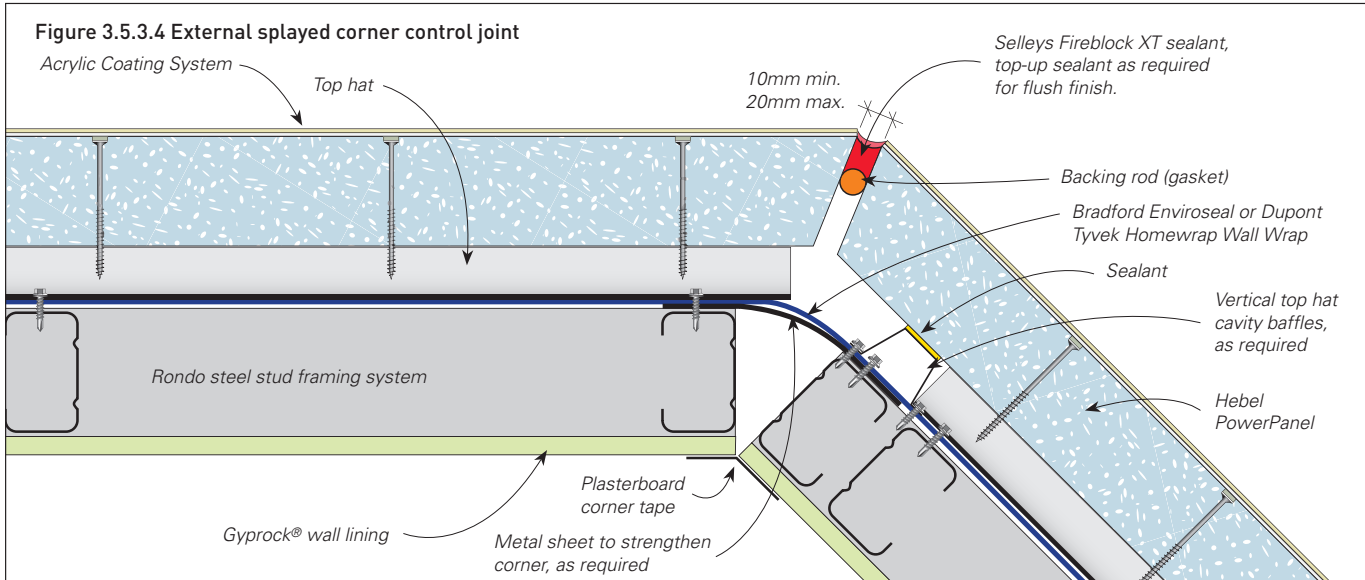

Figure 3.5.3.9 Hebel facade to Hebel internal wall junction

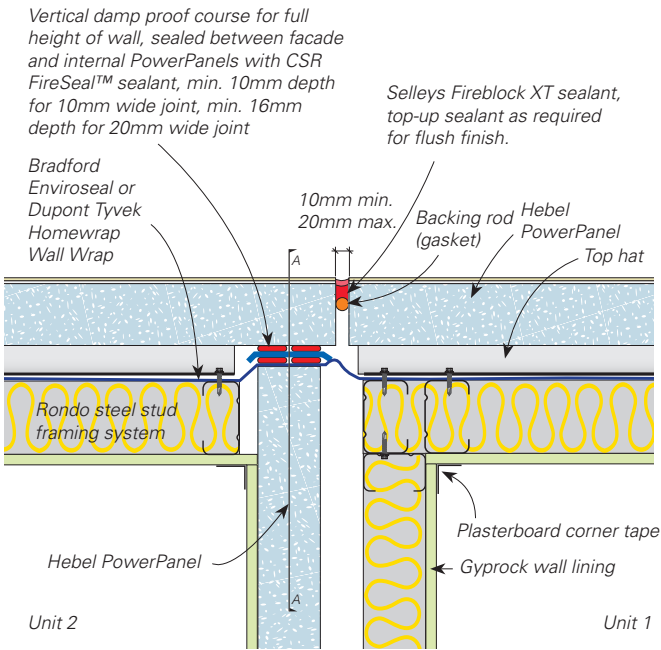
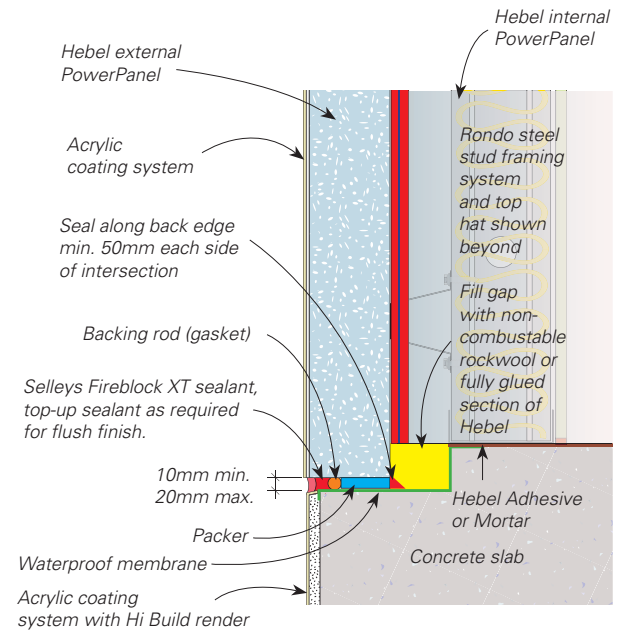

Fig 3.5.3.10 Section AA Hebel facade to Hebel internal wall junction



3.5.4 WINDOWS AND DOORS

Figure 3.5.4.1 Window head (sliding door similar)

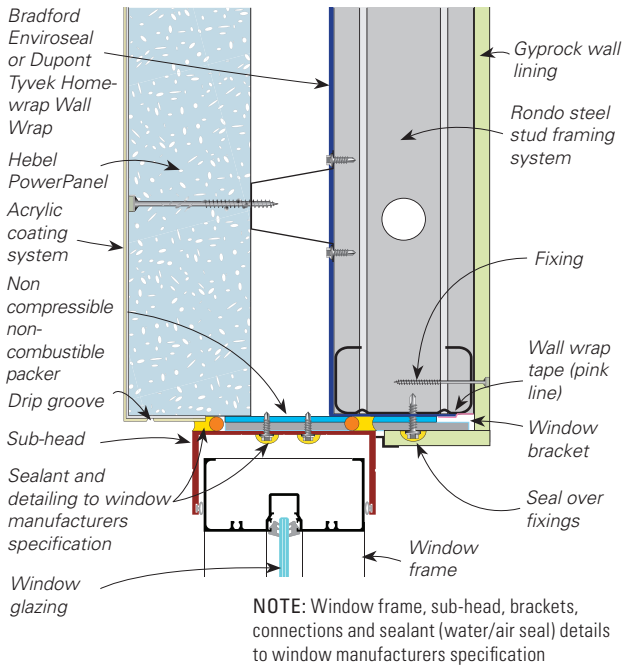

Figure 3.5.4.2 Full height window head with shelf angle (sliding door similar)

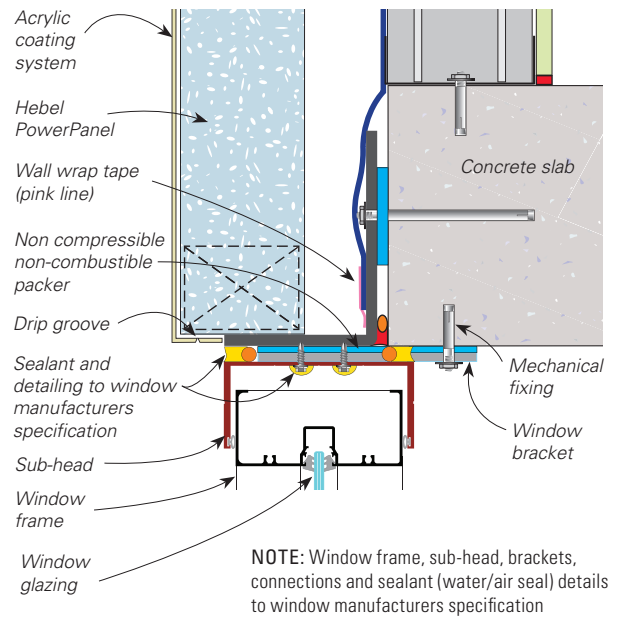

Figure 3.5.4.3 Window jamb (sliding door similar)

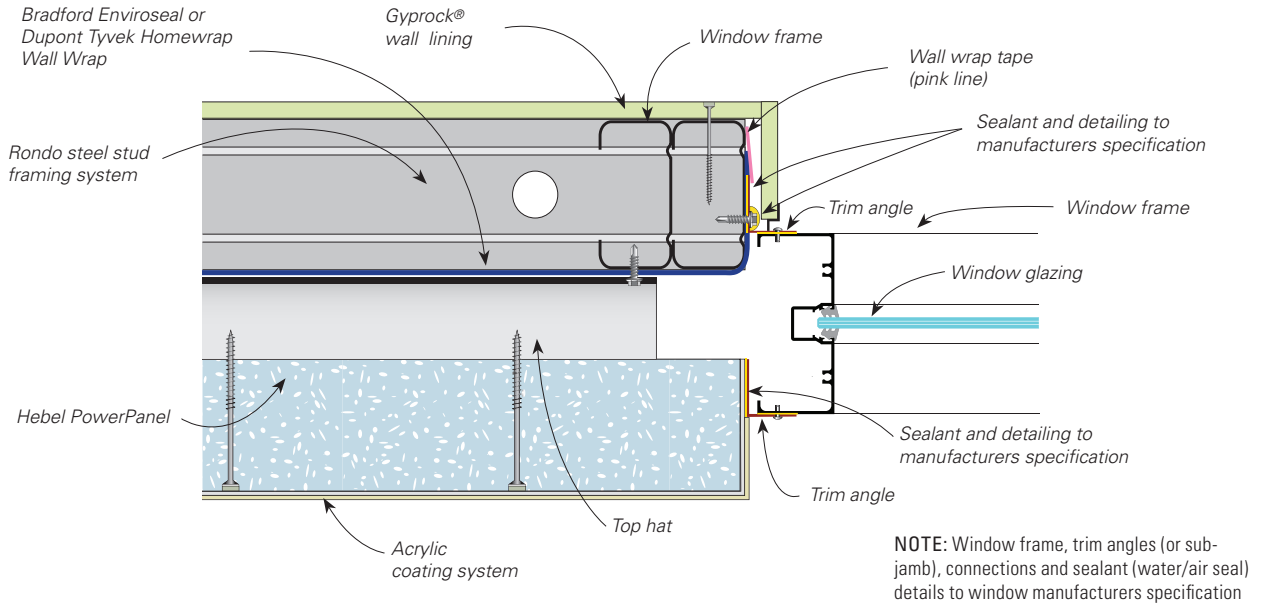
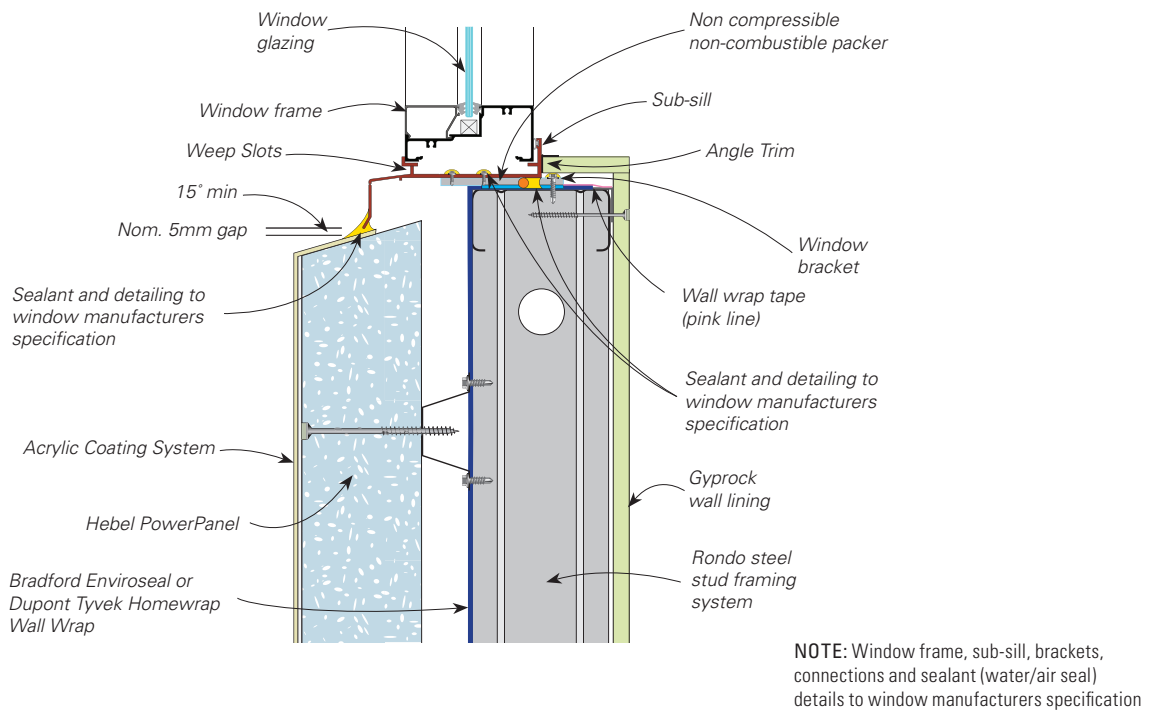

Figure 3.5.4.4 Window sill



3.5.5 BALCONIES

Figure 3.5.5.1 Base junction with double slab step

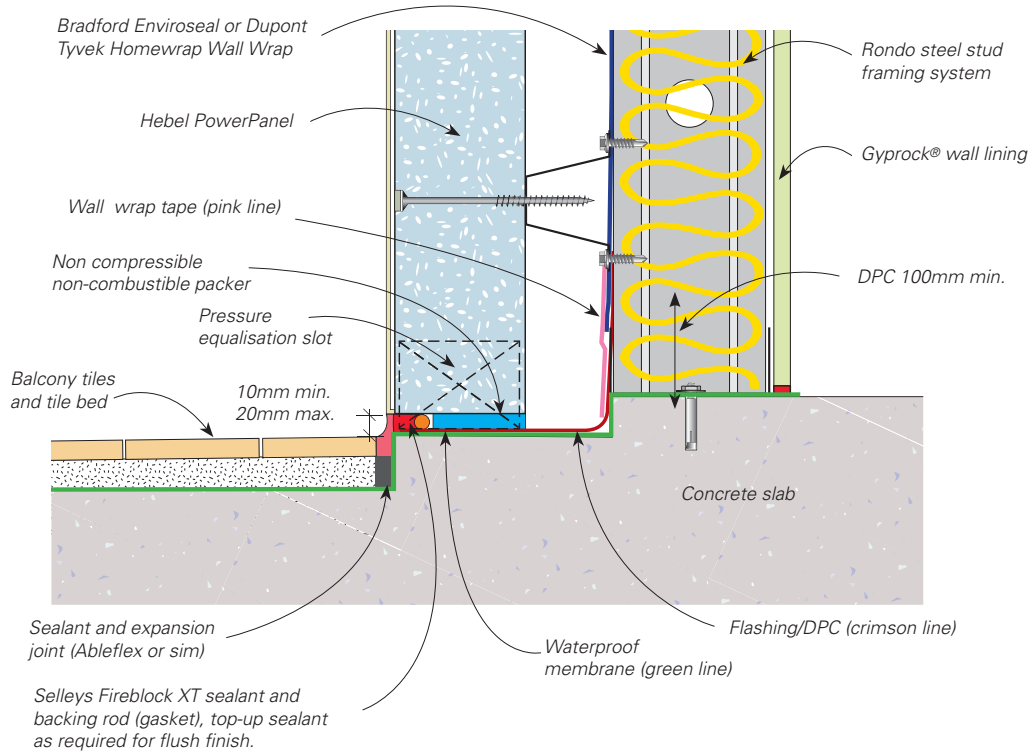
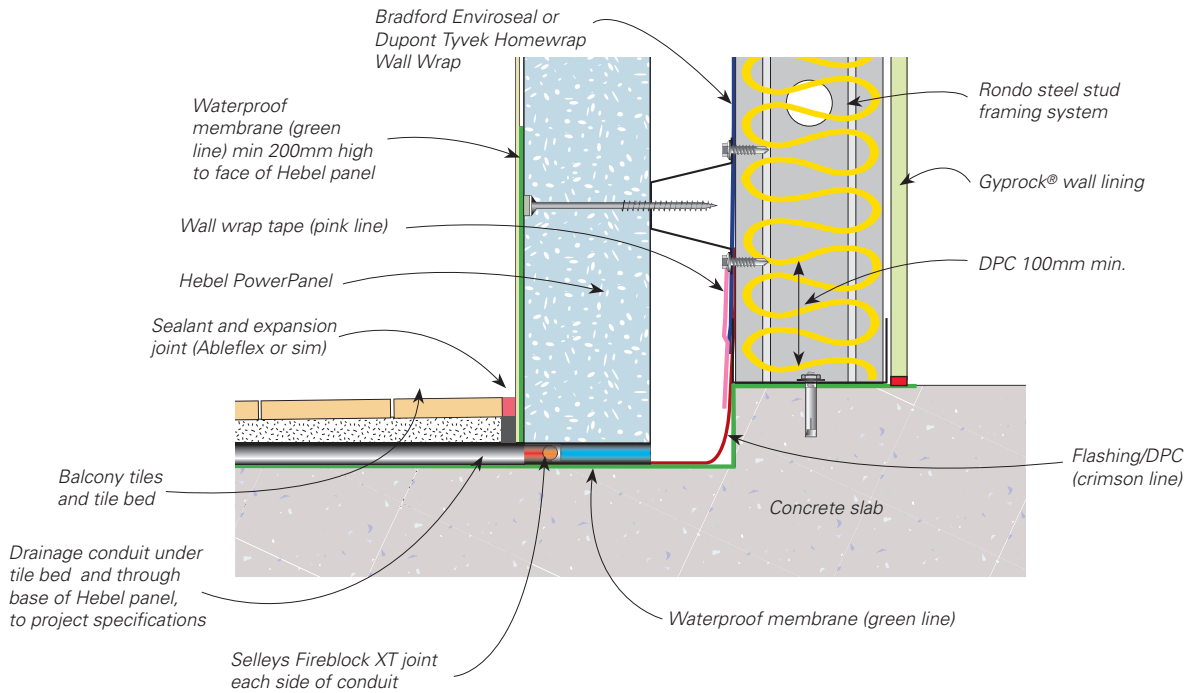

Figure 3.5.5.2 Base junction with drainage conduit



NOTE: Pressure equalisation slots are to be installed at the tops of panels at a max. 3.0m cts for balconies greater than 3m in width.

3.5.6 BALCONY BLADE WALLS

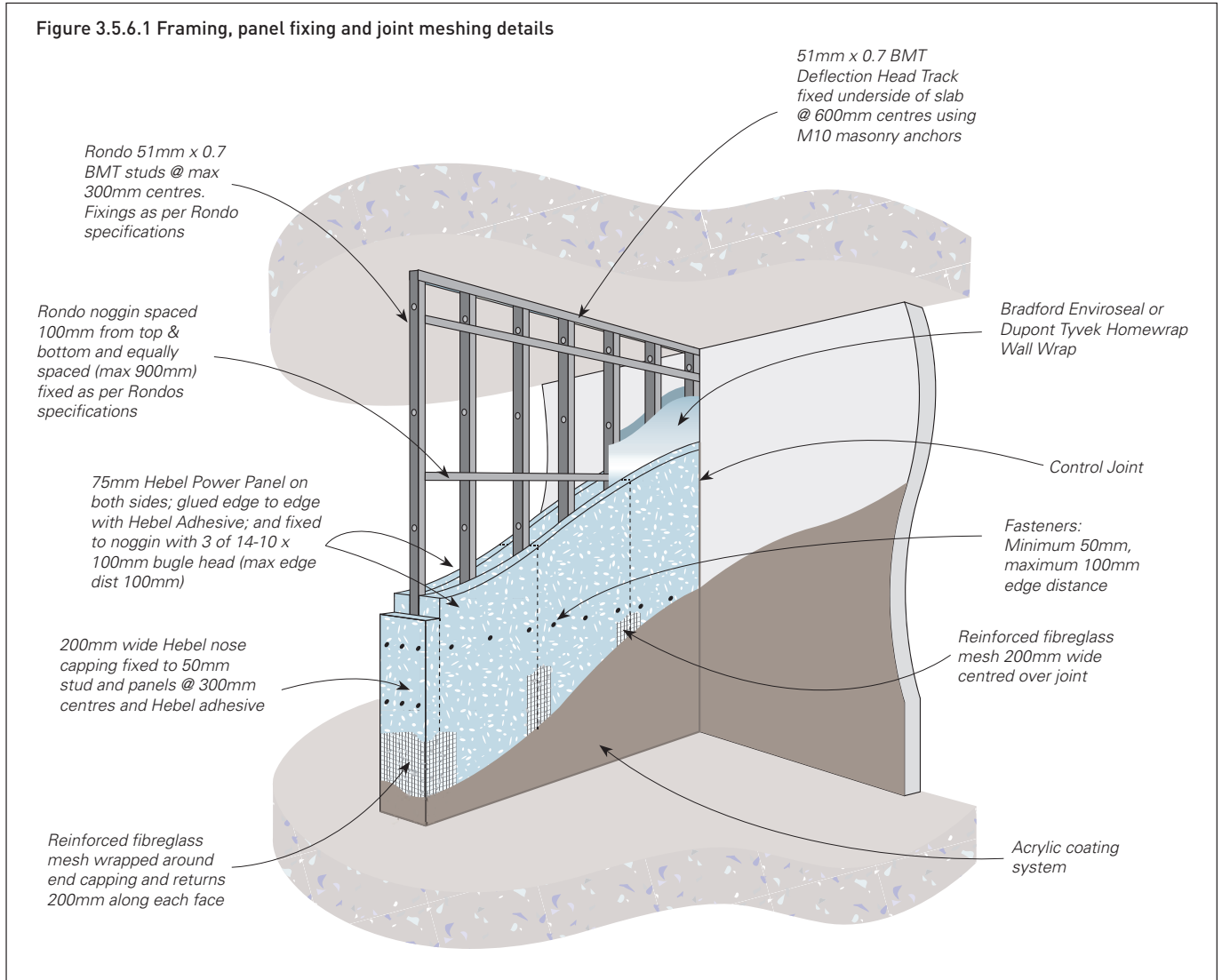

Table 3.5.6.2 Fixing details

Fixings Tables	
Deflection head to underside of slab	M10 Ramset Dynabolt or equivalent spaced @ max 600mm centres max. Edge distance \geq 100mm, min. 90mm Embedment
Base track to slab	as per head track
Stud to btm track	#10-16 Hex Head self drilling screw 1 fixing per side
Noggin to stud	#10-16 Hex Head self drilling screw 1 fixing per side
75mm Hebel PowerPanel to noggin	#14-10x100mm bugle head 3 per noggin per panel max edge distance 100mm
End capping to panels and stud	#14-10 x 150mm hex head coarse thread screws, 3 fixings at 300mm vertical centres

Figure 3.5.6.3 Head and base junctions

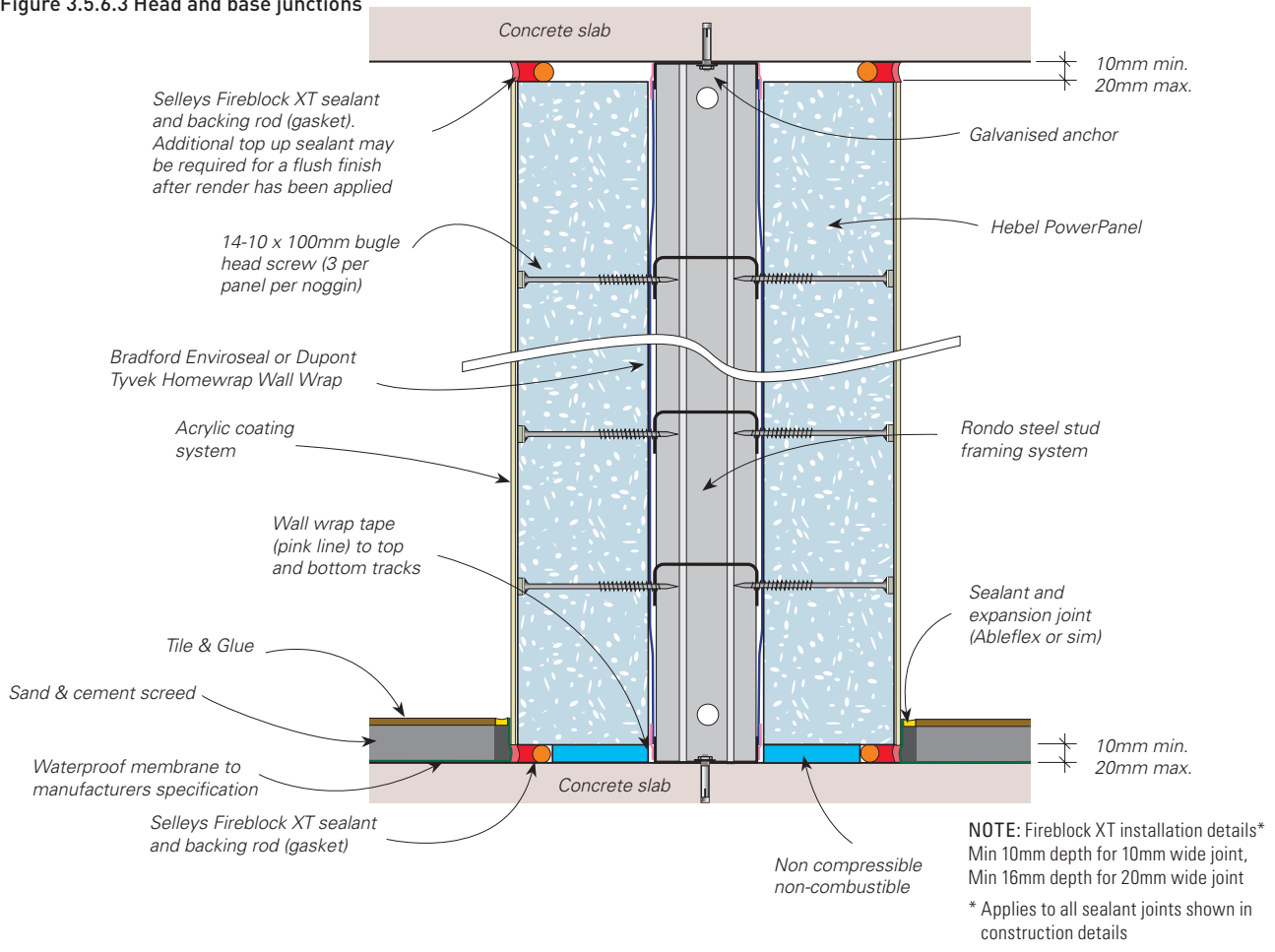
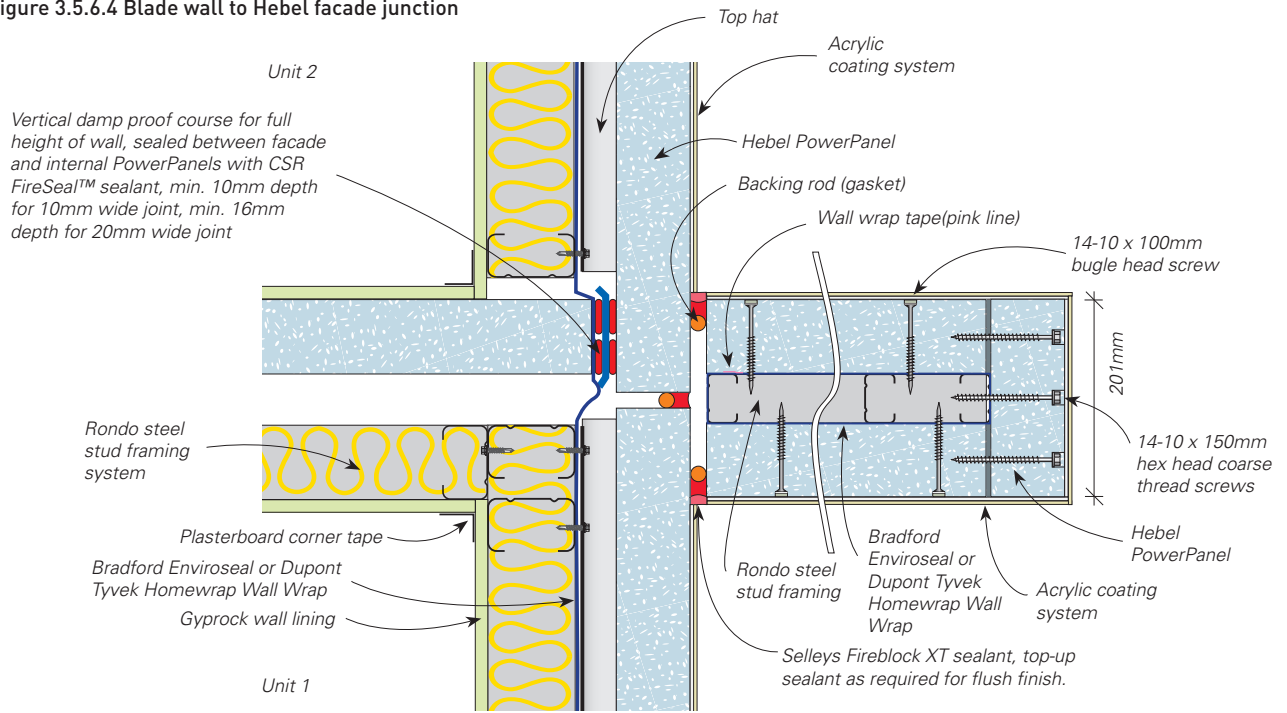
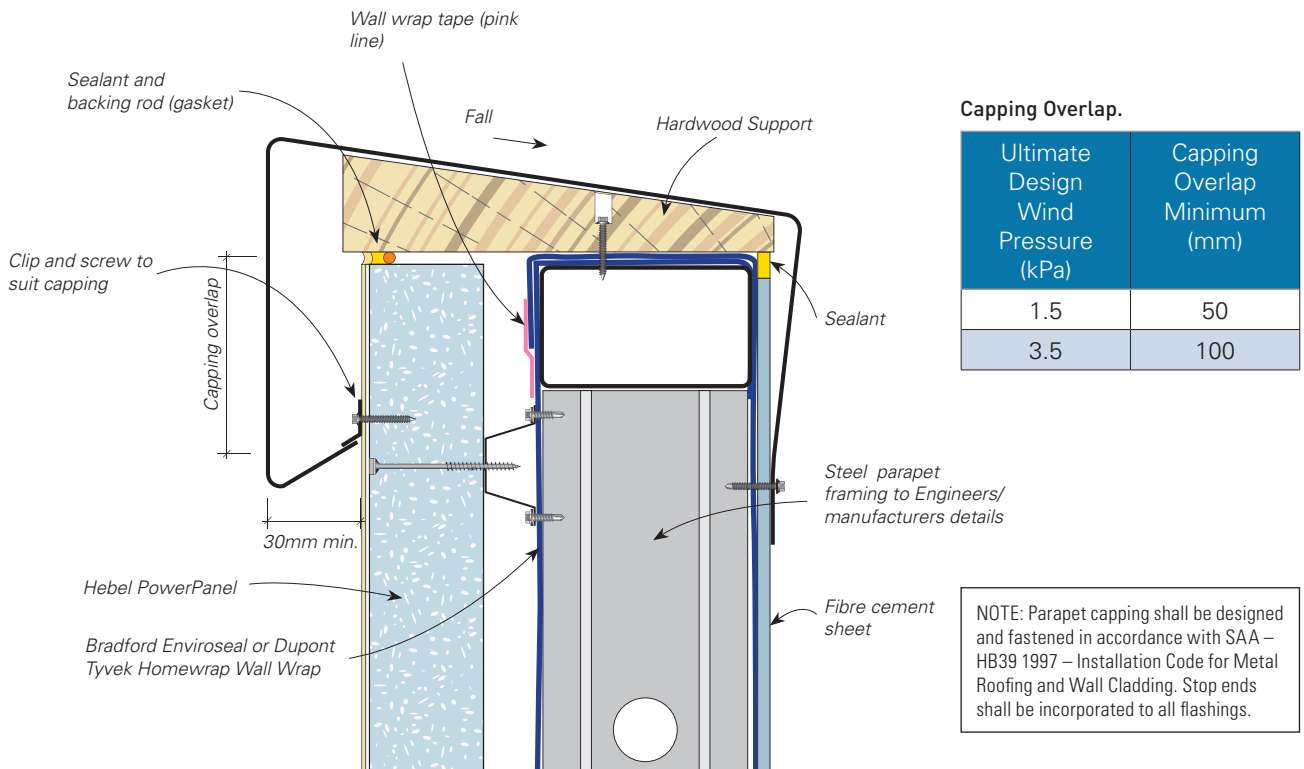

Figure 3.5.6.4 Blade wall to Hebel facade junction



3.5.7 ADDITIONAL DETAILS

Figure 3.5.7.1 Parapet Capping



4.1 CONSTRUCTION DETAILS – ADDITIONAL DETAILS

CSR Hebel engages independent testing laboratories to test and report on the performance of a wall in accordance with the relevant Australian Standards.

Consultants use these reports as the basis for opinions they issue for variations or different arrangements to the tested system, and also to design and specify walls that meet appropriate criteria for a particular project.

Using their experience, the consultant will make judgements about on-site installed performance of various walls.

The performance levels of walls documented in this Design Guide are either what is reported in a test or the documented opinion of consultants.

Performance in projects is typically the responsibility of:

PROJECT CONSULTANTS

- Opinions on expected laboratory performance of wall configurations that vary from actual test configuration, such as substitution products and components.
- Judgements about expected field performance using laboratory test reports and practical experience.
- Design, specification and certification of acoustic, thermal, fire, structural, weather tightness, durability and any other required performance criteria for individual projects. This involves the design and selection of building elements, such as walls and floors and their integration in the building considering the following:
 - Interface of different building elements and to the structure/substrate.
 - Wall and floor junctions.
 - Penetrations.
 - Flanking issues.
 - Room/building geometry.
- Acoustic and water penetration field testing.

PROJECT CERTIFIER AND / OR BUILDER

- Identifying the performance requirements for the project in accordance with the Building Code of Australia and clearly communicating this to relevant parties.
- Applicability of any performance characteristics supplied by CSR Hebel including tests and opinions for the project.
- The project consultant's responsibilities detailed above if one is not engaged in the project.

CSR Hebel does not provide consulting services. CSR Hebel only provides information that has been prepared by others and therefore shall not be considered experts in the field.

Any party using the information contained in this Design & Installation Guide or supplied by CSR Hebel in the course of a project must satisfy themselves that it is true, current, accurate and appropriate for the application, consequently accepting responsibility for its use.

It is the responsibility of the architectural designer and engineering parties to ensure that the details in this Design & Installation Guide are appropriate for the intended application.

The recommendations of this guide are formulated along the lines of good building practice, but are not intended to be an exhaustive statement of all relevant data.

CSR Hebel accepts no responsibility for or in connection with the quality of the recommendations or their suitability for any purpose when installed.

CSR Hebel is not responsible for the performance of constructed walls, including field performance, and does not interpret or make judgements about performance requirements in the Building Code of Australia.

BUILDER – FACADE FRAMING SYSTEM

The Rondo Steel Stud Framing System has been tested by CSR Hebel and is the approved wall framing to be used with the Facade System.

In the event that alternative Stud Framing Systems are selected by the builder, then a design certificate must be prepared by the Stud Frame Manufacturer or Project Engineer (in regard to the Stud Framing Specifications) confirming adequacy of the framing system to sustain the project wind loads. This letter of certification must be provided to CSR Hebel prior to commencement of the installation of the Facade System.

Installation of the stud frame must be such that eventual installation of Hebel panels is flush to ensure satisfactory application of coatings. Certification of the stud frame installation must be provided by the stud frame manufacturer or project engineer. Similarly, this letter of certification must be provided to CSR Hebel.

FACADE DESIGN, SPECIFICATION AND PRE-INSTALLATION ACTIVITIES

The following matrix may be used as a guide in the design and specification of the Hebel Facade System in preparation for installation.

Table 4.1.1 Design, specification and pre-installation activities

PRE-INSTALLATION ACTIVITY		Required involvement by		
		PROJECT CONSULTANT	ARCHITECT	BUILDER
1	Determine the project requirements such as acoustics, fire, structural, weathertightness and durability in accordance with the BCA and relevant statutory laws	■	■	
2	Consult the Hebel Facade system design and installation guide and check the Hebel system meets or exceeds the project requirements identified in Activity No. 1	■	■	
3	Create facade architectural specification which should include: <ul style="list-style-type: none"> • Building tolerances for in-situ concrete elements such as columns and slab edges • Stud framing specification including design certification from stud framing manufacturer or project engineer • Nominate control jointing location • Panel layout including penetration location for services 	■	■	
4	Nominate builder to begin construction. Consider likely Hebel installers and coating applicators			■

FACADE INSTALLATION – CRITICAL STAGE INSPECTIONS (CSI)

The following matrix may be used as a guide in organising and scheduling Critical Stage Inspections of the Hebel Facade System.

Table 4.1.2 Critical Stage Inspections (CSI)

CRITICAL STAGE INSPECTION (CSI)		Required attendee(s) at CSI			
		CSR HEBEL	COATING SUPPLIER	HEBEL INSTALLER	BUILDER
1	Scheduling of critical stage inspections, stud specification, control jointing and coating specification	■	■	■	■
2	Set-out and detailing of stud framing installation in accordance with the current Hebel Facade Design & Installation Guide. (Critical Stage Insp.1)	■		■	
3	Set-out and detailing of wall wrap and Top Hats. (Critical Stage Insp.2)	■		■	
4	Confirm panel installation to first wall length (i.e. Sample Wall). (Critical Stage Insp.3)	■	■	■	■
5	Confirm completed panel installation to entire level. (Critical Stage Insp.4)	■		■	■
6	Confirm the coating system and its installation process - identify any areas of concern and prepare appropriate actions to address.		■		■

5.1 DELIVERY AND STORAGE

UNLOADING PANELS

Panels must be unloaded and moved with only approved lifting devices. Before use, the lifting devices should be checked for the required lifting tags. Panels should be unloaded as close as possible to the intended installation area. This will increase work efficiency and minimise the need for secondary lifting.

STORAGE

All materials should be kept dry and preferably stored undercover. Care should be taken to avoid sagging or damage to ends, edges and surfaces.

All Hebel products must be stacked on edge and properly supported off the ground, on a level platform. Panel bundles can be stacked two high.

The project engineer should be consulted as to the adequacy of the structure to support the stacked bundles. Each bundle contains ten PowerPanels. Where bundles are stacked two high the supporting cleats must be vertically aligned to ensure minimal bending of the lower panels. (See Figure 5.1.1). If Hebel PowerPanels are stored outside they must be stored off the ground and protected from the weather.

To provide a level surface we recommend placing temporary joists beneath the supporting cleats.



UNSTRAPPING BUNDLES WITHOUT APPROPRIATE BRACING

Note: Secondary handling increases the risk of panel damage. The repair of damage sustained during lifting and moving is the responsibility of the lifter. Where damage is excessive, panels must be replaced

Figure 5.1.1 Stacking bundles of Hebel PowerPanel

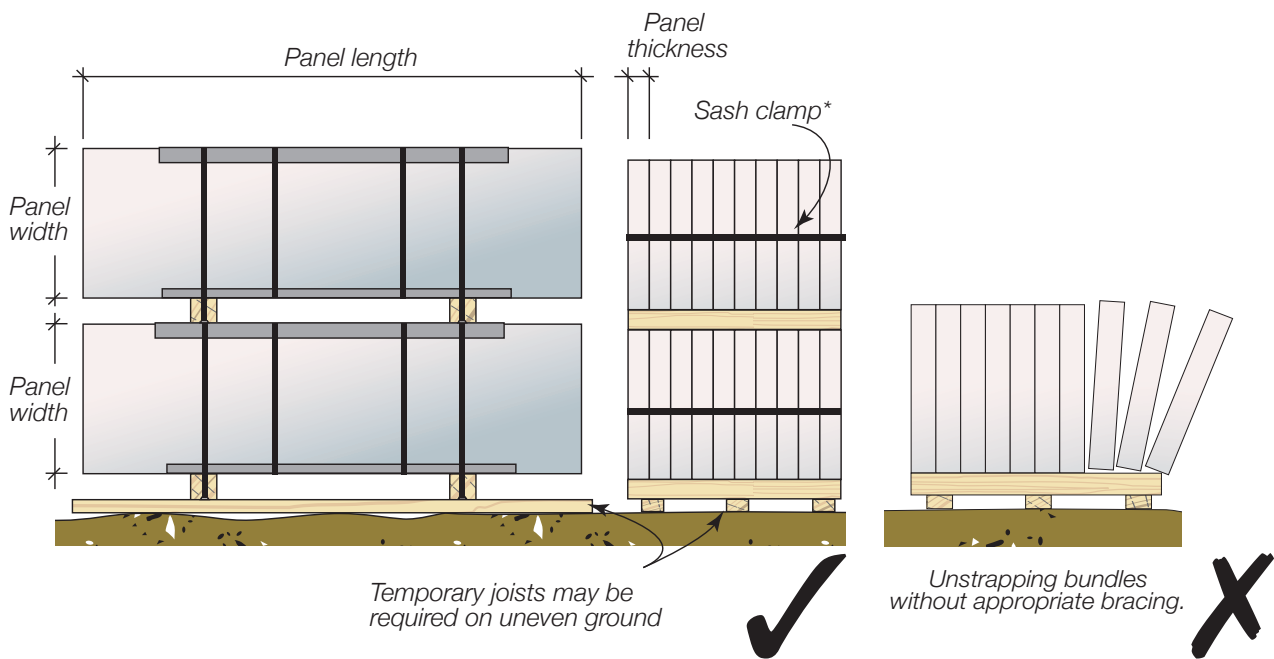

5.2 PANEL HANDLING

MANUAL HANDLING

Hebel recommends using a trolley or other mechanical apparatus to move the panels around the work site. Manual handling where people physically move a panel should be kept to a minimum, with the weight being supported by an individual kept as small as possible. Any concerns regarding the weight to be handled should be discussed with the panel installation contractor.

To minimise the possibility of manual handling injuries Hebel suggests the following:

- use mechanical aids such as trolleys, forklifts, lifters, cranes and levers, or team lifting to move panels
- keep the work place clean to reduce the risk of slips, trips and falls, which can cause injury
- plan the sequence of installation to minimise panel movements and avoid awkward lifts
- train employees in good lifting techniques to minimise the risk of injury.

Hebel Panel Lifters are used for positioning panel in wall.



Hebel Panel Trolleys for easier and safer handling and cutting of Hebel PowerPanels.



TROLLEY ASSISTED HANDLING

Hebel has developed a trolley to allow easier and safer handling of Hebel PowerPanel onsite. There is a range of trolleys to suit panels from 1.2m to 4.2m in length.

HEALTH AND SAFETY

Hebel products are cement-based which may irritate the skin resulting in itching and occasionally a red rash. The wearing of gloves and suitable clothing to reduce abrasion and irritation of the skin is recommended when handling Hebel products.

Approved respirators (AS/NZS1715 and AS/NZ1716) and eye protection (AS1336) should be worn at all times when cutting and chasing. Refer to the Hebel Material Safety Data Sheets on our website www.hebel.com.au.

Standard personal protection equipment (PPE).



6.1 APPENDIX 1

MANUFACTURING TOLERANCES

Length	±5mm
Width	±1.5mm
Thickness	±1.5mm
Diagonals (max.)	5mm
Edge Straightness Deviation (max.)	1.5mm

PowerPanel Physical Properties

- 1) Hebel PowerPanel profile and nominal dimensions are shown in Table 1.7 on page 14.
- 2) Nominal dry density = 510 kg/m³.
- 3) Average working density = 663 kg/m³ at 30% moisture content.
- 4) Average service life density = 561 kg/m³ at 10% moisture content.

PowerPanel Strength Properties

- 1) Characteristic Compressive Strength of AAC, $f'_m = 2.8$ MPa.
- 2) Average Compressive Strength of AAC = 3.2 MPa.
- 3) Characteristic Modulus of Rupture, $f'_{ut} = 0.60$ MPa.

PowerPanel Acoustic Properties

- 1) Panel only with no plasterboard or other lining $R_w = 36$ dB, $R_w + C_{tr} = 33$ dB (refer to acoustic test ATF-676).

PowerPanel Thermal Properties

- 1) R-Value of PowerPanel with no plasterboard or other lining = 0.51 m²K/W (4% moisture content).

Fire Hazard Indices

Hebel AAC products have BCA Group Number 1 and also the following early fire hazard indices, determined in accordance with AS1530.3:1990:

Ignitability Index:	0
Spread of Flame Index	0
Heat Developed Index	0
Smoke Developed Index	0-1

Fire Resistance Level (FRL) Ratings

For fire performance characteristics of the Hebel Facade Wall System, refer to Section 2.2 page 23 of this publication.



CSR HEBEL

Triniti 3, 39 Delhi Road
North Ryde NSW 2113, Australia
Telephone +61 2 9235 8000

Health & safety

Information on any known health risks of our products and how to handle them safely is on product packaging and / or the accompanying documentation.

Additional information is listed in the Safety Data Sheet (SDS). To obtain a copy of a SDS, download from www.hebel.com.au. Contractors are required by law to perform their own risk assessments before undertaking work.

Performance & certification

Hebel® products and systems are developed in Australia by CSR Building Products. ABN. 55 008 631 356. It is a manufacturer and supplier of Hebel Autoclaved Aerated Concrete (AAC) products. Because it is a manufacturer and supplier only, CSR does not employ people qualified as Accredited or Principal Certifiers.

CSR is therefore unable to provide Construction Compliance Certificates or Statements of Compliance. CSR conducts appropriate testing of its products and systems to determine performance levels. These include structural, fire and acoustic tests. Testing is conducted and certified by appropriate specialists in these fields. When using Hebel products and systems in specific projects, such specialists should be consulted to ensure compliance with the Building Code of Australia and relevant Australian Standards.

Disclaimer

Information presented in this document is supplied in good faith and to the best of our knowledge was accurate at the time of preparation. The provision of this information should not be construed as a recommendation to use any of our products in violation of any patent rights or in breach of any statute or regulation. Users are advised to make their own determination as to the suitability of this information in relation to their particular purpose or specific circumstances. Since the information contained in this document may be applied under conditions beyond our control, no responsibility can be accepted by CSR, or its staff for any loss or damage caused by any person acting or refraining from action as a result of misuse of this information.

Other

The design of a wall, floor or fence system requires the services of professional consultants. This document has been prepared as a source of information to provide general guidance to those consultants – and in no way replaces the services of the professional consultant and relevant engineers designing the project.

No liability can therefore be accepted by CSR or other parties for the use of this document. Hebel products and systems undergo constant research and development to integrate new technology and reflect ongoing performance enhancement.

Hebel systems are constantly reviewed so as to reflect any changes in legislative building requirements and or general developments in common building practice, due to our commitment to continual development and improving our building systems.

We advise that all users of this document should regularly check that this document is current, and they are applying our latest design information.

The latest editions of our documents are available on our website:

www.hebel.com.au

Hebel® is a registered trademark of the Xella group. CSR Building Products Ltd is an exclusive licensee of Xella. CSR Hebel is a business of CSR Building Products Ltd ABN 55 008 631 356.

PowerPanel®, PowerBlock® and PowerFloor® are registered trademarks of CSR Building Products Limited.

THE BETTER WAY TO BUILD

Hebel is a quality building product, and is backed by CSR Building Products Limited.

For more information visit our website:

www.hebel.com.au

For sales enquiries or further information, please telephone us from anywhere in Australia:

1300 369 448

